

SENSAPHONE®
IMS-1000

User's Manual

Version 1.4

Every effort has been made to ensure that the information in this document is complete, accurate and up-to-date. Sensaphone assumes no responsibility for the results of errors beyond its control. Sensaphone also cannot guarantee that changes in equipment made by other manufacturers, and referred to in this manual, will not affect the applicability of the information in this manual.

Copyright © 2007 by Sensaphone

First Edition, version 1.4, June 2009

Written and produced by Sensaphone.

Please address comments on this publication to:

Sensaphone
901 Tryens Road
Aston, PA 19014

Important Safety Instructions

Your IMS-1000 has been carefully designed to give you years of safe, reliable performance. As with all electrical equipment, however, there are a few basic precautions you should take to avoid hurting yourself or damaging the unit:

- Read the installation and operating instructions in this manual carefully. Be sure to save it for future reference.
- Read and follow all warning and instruction labels on the product itself.
- To protect the IMS-1000 from overheating, make sure all openings on the unit are not blocked. Do not place on or near a heat source, such as a radiator or heat register.
- Do not use your IMS-1000 near water, or spill liquid of any kind into it.
- Be certain that your power source matches the rating in the specifications of this manual. If you're not sure of the type of power supply to your facility, consult your dealer or local power company.
- Do not allow anything to rest on the power cord. Do not locate this product where the cord will be abused by persons walking on it.
- Do not overload wall outlets and extension cords, as this can result in the risk of fire or electric shock.
- Never push objects of any kind into this product through ventilation holes as they may touch dangerous voltage points or short out parts that could result in a risk of fire or electric shock.
- To reduce the risk of electric shock, do not disassemble this product, but return it to Sensaphone Customer Service, or another approved repair facility, when any service or repair work is required. Opening or removing covers may expose you to dangerous voltages or other risks. Incorrect reassembly can cause electric shock when the unit is subsequently used.
- If anything happens that indicates that your IMS-1000 is not working properly or has been damaged, unplug it immediately and follow the procedures in the manual for having it serviced. Return the unit for servicing under the following conditions:
 1. The power cord or plug is frayed or damaged.
 2. Liquid has been spilled into the product or it has been exposed to water.
 3. The unit has been dropped, or the enclosure is damaged.
 4. The unit doesn't function normally when you're following the operating instructions.
- Avoid using a telephone (other than a cordless type) during an electrical storm. There may be a remote risk of electric shock from lightning.
- Do not use the telephone to report a gas leak in the vicinity of the leak.
- To reduce the risk of fire or injury to persons, read and follow these instructions:
 1. Use only the specified type and size battery.
 2. Do not dispose of the battery in a fire. The cell may explode. Check with local codes for possible special disposal instructions.
 3. Do not open or mutilate batteries. Released electrolyte is corrosive and may cause damage to the eyes or skin. It may be toxic if swallowed.

4. Exercise care in handling batteries in order not to short the battery with conducting materials such as rings, bracelets, and keys. The battery or conductor may overheat and cause burns.
5. Remove main power and telephone connections before replacing the battery.

Wichtige Sicherheitshinweise

Ein wesentlicher Aspekt bei der Entwicklung Ihres IMS-1000 war die Gewährleistung eines sicheren und zuverlässigen Betriebs über viele Jahre hinweg. Wie bei allen elektrisch betriebenen Einrichtungen sollten Sie jedoch auch hier einige grundlegende Vorsichtsmaßnahmen beachten, um Schäden am Gerät und Verletzungen zu vermeiden:

- *Die Installations- und Betriebsanweisungen in diesem Handbuch aufmerksam und vollständig durchlesen. Das Handbuch für den Fall aufbewahren, dass Sie es in Zukunft noch mal benötigen.*
- *Alle am Produkt angebrachten Etiketten mit Warnungen und Vorschriften lesen und beachten.*
- *Um das IMS-1000 vor Überhitzung zu schützen, niemals die Lüftungsöffnungen des Geräts blockieren. Das Gerät nicht auf oder in der Nähe einer Wärmequelle (Heizkörper, Heizschacht) aufstellen.*
- *Das IMS-1000 nicht in unmittelbarer Umgebung von Wasser verwenden. Keine Flüssigkeiten in das Systemgehäuse gelangen lassen.*
- *Sicherstellen, dass die verwendete Stromquelle derjenigen entspricht, die in den technischen Daten dieses Handbuchs angegeben ist. Wenn Sie nicht wissen, welche Art von Stromquelle in Ihrer Anlage zum Einsatz kommt, wenden Sie sich an Ihren Händler oder den örtlichen Energieversorger.*
- *Keine Gegenstände auf dem Netzkabel abstellen. Dieses Produkt nicht so aufstellen, dass Personen auf das Netzkabel treten und es beschädigen können.*
- *Netzsteckdosen und Verlängerungskabel nicht überlasten. Es besteht Feuer- und Stromschlaggefahr.*
- *Niemals Gegenstände welcher Art auch immer durch die Lüftungsöffnungen in das Gehäuse des Produkts stecken, da die Gefahr besteht, dass spannungsführende Teile berührt oder Kurzschlüssen verursacht werden, die zu einem Brand oder Stromschlag führen können.*
- *Um das Stromschlagrisiko zu senken, das Produkt nicht zerlegen, sondern bei erforderlichen Wartungs- oder Reparaturarbeiten zum Sensaphone-Kundendienst oder zu einer anderen zugelassenen Werkstatt geben. Beim Öffnen oder Entfernen von Abdeckungen und Blenden bestehen verschiedene Gefahren, wie etwa die Möglichkeit des Kontakts mit gefährlichen Spannungen. Ferner kann ein unsachgemäßer Zusammenbau zu einem Stromschlag führen, wenn das Gerät anschließend in Betrieb genommen wird.*
- *Wenn Sie feststellen, dass Ihr IMS-1000 nicht einwandfrei funktioniert oder beschädigt wurde, das Gerät umgehend vom Netz trennen und die im Handbuch stehende Anleitung zur Kontrolle und Reparatur befolgen.*

Das Gerät unter folgenden Umständen in Reparatur geben:

1. *Netzkabel oder -stecker sind verschlissen oder beschädigt.*
2. *Flüssigkeit ist in das Gehäuse eingedrungen, oder das Produkt ist mit Wasser in Berührung gekommen.*

3. *Das Gerät wurde fallengelassen oder das Gehäuse ist beschädigt.*
 4. *Das Gerät funktioniert trotz Beachtung der Betriebsanleitung nicht einwandfrei.*
- *Während eines Gewitters kein schnurgebundenes Telefon verwenden. Es besteht Stromschlagrisiko durch Blitzeinschlag.*
 - *Gasaustritt niemals telefonisch melden, wenn Sie sich in unmittelbarer Umgebung des Gaslecks befinden.*
 - *Um das Feuer- und Verletzungsrisiko zu verringern, die folgenden Anweisungen lesen und beachte:*
 1. *Nur Akkumulatoren verwenden, die nach Typ und Größe der Herstellerempfehlung entsprechen.*
 2. *Akkumulatoren nie ins Feuer werfen. Es besteht Explosionsgefahr. Gesetzliche Entsorgungsvorschriften beachten.*
 3. *Akkumulatoren nicht öffnen oder beschädigen. Der freigesetzte Elektrolyt ist ätzend und kann Augen- und Hautschäden verursachen. Bei Verschlucken besteht Vergiftungsgefahr.*
 4. *Beim Umgang mit Akkumulatoren mit Sorgfalt vorgehen, damit die Pole nicht durch leitende Materialien wie Ringe, Armbänder oder Schlüssel kurzgeschlossen werden. Es besteht die Gefahr der Erhitzung von Akkumulator oder Leiter und infolgedessen Verbrennungsgefahr.*
 5. *Netz- und Telefonleitungen vor Austausch des Akkumulators trennen.*

FCC Requirements

Part 68: The Sensaphone IMS-1000 complies with 47 CFR, Part 68 of the rules. On the back of the unit there is a label that contains, among other information, the Certification Number and the Ringer Equivalence Number (REN) for this equipment. You must, upon request, provide this information to your local telephone company.

The REN is useful to determine the quantity of devices that you may connect to your telephone line and still have all of those devices ring when your telephone number is called. In most, but not all areas, the sum of the REN's of all devices connected to one line should not exceed five (5.0). To be certain of the number of devices that you may connect to your line, you may want to contact your local telephone company to determine the maximum REN for your calling area.

The applicable certification jack USOC for this equipment is: RJ11C. The facility interface code (FIC) for this equipment is: 02LS2.

A compliant telephone cord and modular plug are provided with equipment. This equipment is designated to be connected to the telephone network or premises wiring using a compatible modular jack which is Part 68 compliant. See Installation Instructions for details.

This equipment may not be used on coin service units provided by the telephone company. Connection to party lines is subject to state tariffs. Contact the state public utility commission, public service commission or corporation commission for information.

Should the IMS-1000 cause harm to the telephone network, the telephone company may discontinue your service temporarily. If possible, they will notify you in advance. But if advance notice isn't practical, the telephone company may temporarily discontinue service without notice and you will be notified as soon as possible. You will be informed of your right to file a complaint with the FCC. The telephone company may make changes in its facilities, equipment, operations, or procedures where such action is reasonably required in the operation of its business and is not inconsistent with the rules and regulations of the FCC that could affect the proper functioning of your equipment. If they do, you will be notified in advance to give you an opportunity to maintain uninterrupted telephone service.

If you experience trouble with the Sensaphone IMS-1000, or you need information on obtaining service or repairs, please contact:

Phonetics, Inc.

901 Tryens Road, Aston, PA 19014

610.558.2700

Fax: 610.558.0222

If the equipment is causing harm to the telephone network, the telephone company may ask that you disconnect this equipment from the network until the problem has been corrected or until you are sure that the equipment is not malfunctioning.

Part 15: This equipment has been tested and found to comply with the limits for a Class A digital device, pursuant to Part 15 of the FCC Rules. These limits are designed to provide reasonable protection against harmful interference when the equipment is operated in a commercial environment. This equipment generates, uses and can radiate radio frequency energy and, if not installed and used in accordance with the instructions, may cause harmful interference to radio communications. Operation of this equipment in a residential area is likely to cause harmful interference in which case the user will be required to correct the interference at his own expense.

Telephone Consumer Protection Act

The FCC Telephone Consumer Protection Act of 1991 makes it unlawful for any person to use a computer or other electronic device, including FAX machines, to send a message unless such message contains, in a margin at the top or bottom of each transmitted page or on the first page of the transmission, the date and time it is sent and an identification of the business or other entity, or other individual sending the message, and the telephone number of the sending machine or such business, other entity, or individual. (The telephone number provided may not be a 900 number or any other number for which charges exceed local or long-distance transmission charges.)

To comply with this law, you must enter the following information into your IMS-1000:

- Date, Time and Unit Name as described in the System Settings section of the Manual.
- Unit telephone number to identify the source of the FAX transmission, as shown in the Modem Settings section of the Manual.

General Requirements for all Automatic Dialers

When programming emergency numbers and (or) making test calls to emergency numbers:

1. Remain on the line and briefly explain to the dispatcher the reason for the call.
2. Perform such activities in the off-peak hours, such as early morning or late evenings.

Canadian Department of Communications Statement

Notice: The Canadian Department of Communications label identifies certified equipment. This certification means that the equipment meets certain telecommunications network protective operational and safety requirements. The Department does not guarantee the equipment will operate to the user's satisfaction.

Before installing this equipment, users should ensure that it is permissible to be connected to the facilities of the local telecommunications company. The equipment must also be installed using an acceptable method of connection. In some cases, the company's inside wiring associated with a single line individual service may be extended by means of a certified connector assembly (telephone extension cord). The customer should be aware that compliance with the above conditions may not prevent degradation of service in some situations.

Repairs to certified equipment should be made by an authorized Canadian maintenance facility designated by the supplier. Any repairs or alterations made by the user to this equipment, or equipment malfunctions, may give the telecommunications company cause to request the user to disconnect the equipment.

Users should ensure for their own protection that the electrical ground connections of the power utility, telephone lines and internal metallic water pipe system, if present, are connected together. This precaution may be particularly important in rural areas.

CAUTION: Users should not attempt to make such connections themselves, but should contact the appropriate electric inspection authority, or electrician, as appropriate.

The Ringer Equivalence Number (REN) assigned to each terminal device denotes the percentage of the total load to be connected to a telephone loop which is used by the device to prevent overloading. The termination on a loop may consist of any combination of devices subject only to the requirement that the total of the Ringer Equivalence Numbers of all the devices does not exceed 5.0. For IMS-1000, the Ringer Equivalence Number is 0.0.

The following Copyright applies to the Graphing features of the IMS web page.

Portions copyright 1994, 1995, 1996, 1997, 1998, 1999, 2000, 2001, 2002 by Cold Spring Harbor Laboratory. Funded under Grant P41-RR02188 by the National Institutes of Health.

Portions copyright 1996, 1997, 1998, 1999, 2000, 2001, 2002 by Boutell.Com, Inc.

Portions relating to GD2 format copyright 1999, 2000, 2001, 2002 Philip Warner.

Portions relating to PNG copyright 1999, 2000, 2001, 2002 Greg Roelofs.

Portions relating to gdttf.c copyright 1999, 2000, 2001, 2002 John Ellson (ellson@lucent.com).

Portions relating to gdfc.c copyright 2001, 2002 John Ellson (ellson@lucent.com).

Portions relating to JPEG and to color quantization copyright 2000, 2001, 2002, Doug Becker and copyright © 1994, 1995, 1996, 1997, 1998, 1999, 2000, 2001, 2002, Thomas G. Lane. This software is based in part on the work of the Independent JPEG Group.

Portions relating to WBMP copyright 2000, 2001, 2002 Maurice Szmurlo and Johan Van den Brande.

Permission has been granted to copy, distribute and modify gd in any context without fee, including a commercial application, provided that this notice is present in user-accessible supporting documentation.

This does not affect your ownership of the derived work itself, and the intent is to assure proper credit for the authors of gd, not to interfere with your productive use of gd. If you have questions, ask. “Derived works” includes all programs that utilize the library. Credit must be given in user-accessible documentation.

This software is provided “AS IS.” The copyright holders disclaim all warranties, either express or implied, including but not limited to implied warranties of merchantability and fitness for a particular purpose, with respect to this code and accompanying documentation.

Although their code does not appear in gd 2.0.4, the authors wish to thank David Koblas, David Rowley, and Hutchison Avenue Software Corporation for their prior contributions.

The following Copyright applies to the Web Server operating within the IMS-1000.

Copyright ©2007 GoAhead Software, Inc. All Rights Reserved.

3 YEAR LIMITED WARRANTY

PLEASE READ THIS WARRANTY CAREFULLY BEFORE USING THE PRODUCT.

THIS LIMITED WARRANTY CONTAINS SENSAPHONE'S STANDARD TERMS AND CONDITIONS. WHERE PERMITTED BY THE APPLICABLE LAW, BY KEEPING YOUR SENSAPHONE PRODUCT BEYOND THIRTY (30) DAYS AFTER THE DATE OF DELIVERY, YOU FULLY ACCEPT THE TERMS AND CONDITIONS SET FORTH IN THIS LIMITED WARRANTY.

IN ADDITION, WHERE PERMITTED BY THE APPLICABLE LAW, YOUR INSTALLATION AND/OR USE OF THE PRODUCT CONSTITUTES FULL ACCEPTANCE OF THE TERMS AND CONDITIONS OF THIS LIMITED WARRANTY (HEREINAFTER REFERRED TO AS "LIMITED WARRANTY OR WARRANTY"). IF YOU DO NOT AGREE TO THE TERMS AND CONDITIONS OF THIS WARRANTY, INCLUDING ANY LIMITATIONS OF WARRANTY, INDEMNIFICATION TERMS OR LIMITATION OF LIABILITY, THEN YOU SHOULD NOT USE THE PRODUCT AND SHOULD RETURN IT TO THE SELLER FOR A REFUND OF THE PURCHASE PRICE. THE LAW MAY VARY BY JURISDICTION AS TO THE APPLICABILITY OF YOUR INSTALLATION OR USE ACTUALLY CONSTITUTING ACCEPTANCE OF THE TERMS AND CONDITIONS HEREIN AND AS TO THE APPLICABILITY OF ANY LIMITATION OF WARRANTY, INDEMNIFICATION TERMS OR LIMITATIONS OF LIABILITY.

1. **WARRANTOR:** In this Warranty, Warrantor shall mean "Dealer, Distributor, and/or Manufacturer."
2. **ELEMENTS OF WARRANTY:** This Product is warranted to be free from defects in materials and craftsmanship with only the limitations and exclusions set out below.
3. **WARRANTY AND REMEDY:** Three-Year Warranty — In the event that the Product does not conform to this warranty at any time during the time of three years from original purchase, warrantor will repair the defect and return it to you at no charge.

This warranty shall terminate and be of no further effect at the time the product is: (1) damaged by extraneous cause such as fire, water, lightning, etc. or not maintained as reasonable and necessary; or (2) modified; or (3) improperly installed; or (4) misused; or (5) repaired or serviced by someone other than Warrantors' authorized personnel or someone expressly authorized by Warrantor's to make such service or repairs; (6) used in a manner or purpose for which the product was not intended; or (7) sold by original purchaser.

LIMITED WARRANTY, LIMITATION OF DAMAGES AND DISCLAIMER OF LIABILITY FOR DAMAGES: THE WARRANTOR'S OBLIGATION UNDER THIS WARRANTY IS LIMITED TO REPAIR OR REPLACEMENT OF THE PRODUCT, AT THE WARRANTOR'S OPTION AS TO REPAIR OR REPLACEMENT. IN NO EVENT SHALL WARRANTORS BE LIABLE OR RESPONSIBLE FOR PAYMENT OF ANY INCIDENTAL, CONSEQUENTIAL, SPECIAL AND/OR PUNITIVE DAMAGES OF ANY KIND, INCLUDING BUT NOT LIMITED TO ANY LABOR COSTS, PRODUCT COSTS, LOST REVENUE, BUSINESS INTERRUPTION LOSSES, LOST PROFITS, LOSS OF BUSINESS, LOSS OF DATA OR INFORMATION, OR FINANCIAL LOSS, FOR CLAIMS OF ANY NATURE, INCLUDING BUT NOT LIMITED TO CLAIMS IN CONTRACT, BREACH OF WARRANTY OR TORT, AND WHETHER OR NOT CAUSED BY WARRANTORS' NEGLIGENCE. IN THE EVENT THAT IT IS DETERMINED IN ANY ADJUDICATION THAT THE LIMITED WARRANTIES OF REPAIR OR REPLACEMENT ARE INAPPLICABLE, THEN THE PURCHASER'S SOLE REMEDY SHALL BE PAYMENT TO THE PURCHASER OF THE ORIGINAL COST OF THE PRODUCT, AND IN NO EVENT SHALL WARRANTORS BE LIABLE OR RESPONSIBLE FOR PAYMENT OF ANY INCIDENTAL, CONSEQUENTIAL, SPECIAL AND/OR PUNITIVE DAMAGES OF ANY KIND, INCLUDING BUT NOT LIMITED TO ANY LOST REVENUE, BUSINESS INTERRUPTION LOSSES, LOST PROFITS, LOSS OF BUSINESS, LOSS OF DATA OR INFORMATION, OR FINANCIAL LOSS, FOR CLAIMS OF ANY NATURE, INCLUDING BUT NOT LIMITED TO CLAIMS IN CONTRACT, BREACH OF WARRANTY OR TORT, AND WHETHER OR NOT CAUSED BY WARRANTORS' NEGLIGENCE.

WITHOUT WAIVING ANY PROVISION IN THIS LIMITED WARRANTY, IF A CIRCUMSTANCE ARISES WHERE WARRANTORS ARE FOUND TO BE LIABLE FOR ANY LOSS OR DAMAGE ARISING OUT OF MISTAKES, NEGLIGENCE, OMISSIONS, INTERRUPTIONS, DELAYS, ERRORS OR DEFECTS IN WARRANTORS' PRODUCTS OR SERVICES, SUCH LIABILITY SHALL NOT EXCEED THE TOTAL AMOUNT PAID BY THE CUSTOMER FOR WARRANTORS' PRODUCT AND SERVICES OR \$250.00, WHICHEVER IS GREATER. YOU HEREBY RELEASE WARRANTORS FROM ANY AND ALL OBLIGATIONS, LIABILITIES AND CLAIMS IN EXCESS OF THIS LIMITATION.

INDEMNIFICATION AND COVENANT NOT TO SUE: YOU WILL INDEMNIFY, DEFEND AND HOLD HARMLESS WARRANTORS, THEIR OWNERS, DIRECTORS, OFFICERS, EMPLOYEES, AGENTS, SUPPLIERS OR AFFILIATED COMPANIES, AGAINST ANY AND ALL CLAIMS, DEMANDS OR ACTIONS BASED UPON ANY LOSSES, LIABILITIES, DAMAGES OR COSTS, INCLUDING BUT NOT LIMITED TO DAMAGES THAT ARE DIRECT OR INDIRECT, INCIDENTAL, SPECIAL OR CONSEQUENTIAL, AND INCLUDING ATTORNEYS FEES AND LEGAL COSTS, THAT MAY RESULT FROM

THE INSTALLATION, OPERATION, USE OF, OR INABILITY TO USE WARRANTORS' PRODUCTS AND SERVICES, OR FROM THE FAILURE OF THE WARRANTORS' SYSTEM TO REPORT A GIVEN EVENT OR CONDITION, WHETHER OR NOT CAUSED BY WARRANTORS' NEGLIGENCE.

YOU AGREE TO RELEASE, WAIVE, DISCHARGE AND COVENANT NOT TO SUE WARRANTORS, THEIR OWNERS, DIRECTORS, OFFICERS, EMPLOYEES, AGENTS, SUPPLIERS OR AFFILIATED COMPANIES, FOR ANY AND ALL LIABILITIES POTENTIALLY ARISING FROM ANY CLAIM, DEMAND OR ACTION BASED UPON ANY LOSSES, LIABILITIES, DAMAGES OR COSTS, INCLUDING BUT NOT LIMITED TO DAMAGES THAT ARE DIRECT OR INDIRECT, INCIDENTAL, SPECIAL OR CONSEQUENTIAL, AND INCLUDING ATTORNEYS FEES AND LEGAL COSTS, THAT MAY RESULT FROM THE INSTALLATION, OPERATION, USE OF, OR INABILITY TO USE WARRANTORS' PRODUCTS AND SERVICES, OR FROM THE FAILURE OF THE WARRANTORS' SYSTEM TO REPORT A GIVEN EVENT OR CONDITION, WHETHER OR NOT CAUSED BY WARRANTORS' NEGLIGENCE, EXCEPT AS NECESSARY TO ENFORCE THE EXPRESS TERMS OF THIS LIMITED WARRANTY.

EXCLUSIVE WARRANTY: THE LIMITED WARRANTY OR WARRANTIES DESCRIBED HEREIN CONSTITUTE THE SOLE WARRANTY OR WARRANTIES TO THE PURCHASER. ALL IMPLIED WARRANTIES ARE EXPRESSLY DISCLAIMED, INCLUDING: THE WARRANTY OF MERCHANTABILITY AND THE WARRANTY OF FITNESS FOR A PARTICULAR USE AND THE WARRANTY OF FITNESS FOR A PARTICULAR PURPOSE AND THE WARRANTY OF NON-INFRINGEMENT AND/OR ANY WARRANTY ARISING FROM A COURSE OF DEALING, USAGE, OR TRADE PRACTICE.

It must be clear that the Warrantors are not insuring your premises or business or guaranteeing that there will not be damage to your person or property or business if you use this Product. You should maintain insurance coverage sufficient to provide compensation for any loss, damage, or expense that may arise in connection with the use of products or services, even if caused by Warrantors' negligence. The warrantors assume no liability for installation of the Product and/or interruptions of the service due to strikes, riots, floods, fire, and/or any cause beyond Seller's control, further subject to the limitations expressed in any License Agreement or other Agreement provided by Warrantors to purchaser.

The agreement between the Warrantors and the Purchaser, including but not limited to the terms and conditions herein shall not be governed by the Convention for the International Sale of Goods. Where applicable, the Uniform Commercial Code as adopted by the State of Delaware shall apply.

4. PROCEDURE FOR OBTAINING PERFORMANCE OF WARRANTY: In the event that the Product does not conform to this warranty, the Product should be shipped or delivered freight prepaid to a Warrantor with evidence of original purchase.

5. LEGAL REMEDIES AND DISCLAIMER: Some jurisdictions may not allow, or may place limits upon, the exclusion and/or limitation of implied warranties, incidental damages and/or consequential damages for some types of goods or products sold to consumers and/or the use of indemnification terms. Thus, the exclusions, indemnification terms and limitations set out above may not apply, or may be limited in their application, to you. If the implied warranties can not be excluded, and the applicable law permits limiting the duration of implied warranties, then the implied warranties herein are to be limited to the same duration as the applicable written warranty or warranties herein. The warranty or warranties herein may give you specific legal rights that will depend upon the applicable law. You may also have other legal rights depending upon the law in your jurisdiction.

6. CHOICE OF FORUM AND CHOICE OF LAW: In the event that a dispute arises out of or in connection with this Limited Warranty, then any claims or suits of any kind concerning such disputes shall only and exclusively be brought in either the Court of Common Pleas of Delaware County, Pennsylvania or the United States District Court for the Eastern District of Pennsylvania.

Regardless of the place of contracting or performance, this Limited Warranty and all questions relating to its validity, interpretation, performance and enforcement shall be governed by and construed in accordance with the laws of the State of Delaware, without regard to the principles of conflicts of law.

Effective date 05/01/2004
PHONETICS, INC. d.b.a. SENSAPHONE
901 Tryens Road
Aston, PA 19014
Phone: 610.558.2700 Fax: 610.558.0222
www.sensaphone.com

Table of Contents

Important Safety Instructionsiii
Wichtige Sicherheitshinweise.	iv
FCC Requirements	vi
Telephone Consumer Protection Act.	vii
General Requirements for all Automatic Dialers.	vii
Canadian Department of Communications Statement	vii
3 YEAR LIMITED WARRANTY.	ix
Chapter 1: Installation	19
Introduction	19
Features	19
Technical Support	19
About This Manual.	19
INSTALLATION and CONFIGURATION.	20
Physical Description	20
Front Panel Layout	20
RJ-45 10/100BASE-T Ethernet Port	20
Phone Jack (optional).	20
Sensor Inputs.	20
Sensor Input LEDs	21
USB Expansion Port.	21
Relay Output	21
System On LED	21
Battery Ok LED	21
Alarm LED	22
Rear Panel	22
ON/OFF Switch.	22
Installation	22
Parts Required	22
Operating Environment	23

- Rack Mount Installation 23**
- Tabletop Installation 23
- Power On Self Test (POST) 23
- Connecting Sensors. 24
- Network Configuration 24**
- Parameter Descriptions 26**
- Battery Maintenance 27**
- Service life 27
- Replacing the Battery 27
- Akkumulator austauschen. 28
- IMS-1000 Specifications 30**
- Operating Specifications 30
- Communications Specifications. 30
- Environmental Monitoring 30
- Chapter 2: IMS-1000 Programming . . . 31**
- Introduction 31**
- Configuring the System Settings 31
- System Settings. 31
- Network Settings 32
- Remote Web Page 32
- Viewing the Remote Web Page 33
- Modem Settings. 33
- Voice Settings 34**
- Template Settings 34**
- Configure User Profiles and Contacts 34**
- Deleting a Profile 35
- Contacts 35**
- Voice Calls. 36
- Numeric Pager Calls 36
- Alphanumeric Pager / Cell Phone Text Message 36
- Fax Calls 37
- E-mail 37
- SNMP 37
- Connect Environmental Sensors 37**

Configuring Environmental Inputs	38
Environmental Input Alarm Logic	39
Trouble Alarms	39
Special Notes	40
Configuring IP Alarms	40
IP Alarm Setup	40
Programming Alarm Parameters	40
Alarm Logic	42
Removing an IP Alarm	43
Configuring a Network Video Camera	44
Alarm Response via the Camera	44
Camera Snapshots on Alarm	44
Voice Recording and Assignment	45
Channel View	47
History	47
Viewing History	48
Exporting Data	48
Deleting Eventlog Records	48
Deleting Datalog Records	48
SMTP Error messages	48
Saving and Loading Programming	49
Updating Firmware	49
Resetting to Factory Defaults	49
Configuring the Relay Output	50
Modes of Operation	51
Setting the Output Mode	51
Manual Output Mode	51
Alarm Condition and Unacknowledged Alarm Mode	52
Touch-Tone Control	52
Chapter 3: Operation	53
Alarm Delivery and Acknowledgment	53
Alarm Acknowledgment	53
Sample Alarm Messages	54
Sample E-mail alarm message	54

Sample Fax message 54

Sample Alphanumeric Pager Message..... 54

Voice Alarm Dialout 55

Call-in Alarm Acknowledgment..... 56

Chapter 4: SNMP
(Simple Network Management Protocol) 57

Chapter 5: IMS-1000 Sensors 59

IMS-4810 Room Temperature Sensor 59

Installation Instructions 59

 Introduction..... 59

 Package Contents..... 59

 Cabling 59

 Mounting..... 59

 Electrical box installation..... 59

 Hidden cable surface installation..... 60

 Visible cable surface installation 60

 Configuration 61

 Fahrenheit/Celsius Selection..... 61

 Sensor Template (*factory default*) 62

 Specifications..... 62

IMS-4811 Room Temperature Sensor with display
(Fahrenheit) 63

Installation Instructions 63

 Introduction..... 63

 Package Contents..... 63

 Cabling 63

 Mounting..... 63

 Electrical box installation..... 63

 Hidden cable surface installation..... 64

 Visible cable surface installation 64

 Configuration 65

 Sensor Template (*factory default*) 65

 Specifications..... 65

IMS-4812 Mini-Temperature Sensor (Fahrenheit) 66

Installation Instructions	66
Introduction.	66
Cabling	66
Mounting.	66
Configuration	66
Sensor Template (<i>factory default</i>)	67
Specifications.	67
IMS-4813 Room Temperature Sensor with display (Celsius)	68
Installation Instructions	68
Introduction.	68
Cabling	68
Mounting.	68
Electrical box installation.	68
Hidden cable surface installation.	69
Visible cable surface installation	69
Configuration	70
Sensor Template (<i>factory default</i>)	70
Specifications.	70
IMS-4814 Ultra Low Temperature Sensor	71
Installation Instructions	71
Introduction.	71
Mounting.	71
Configuration.	71
Sensor Template.	72
Specifications	72
IMS-4820 Room Humidity Sensor	73
Installation Instructions	73
Introduction.	73
Cabling	73
Mounting.	73
Electrical box installation.	73
Hidden cable surface installation.	74
Visible cable surface installation	74
Configuration	75
Sensor Template (<i>factory default</i>)	75

- Specifications.75
- IMS-4821 Room Humidity Sensor with display76**
- Installation Instructions76**
 - Introduction.76
 - Cabling76
 - Mounting.76
 - Electrical box installation.76
 - Hidden cable surface installation.77
 - Visible cable surface installation77
 - Configuration78
 - Sensor Template (*factory default*)78
 - Specifications.78
- IMS-4830 Water Detection Sensor79**
- Installation Instructions79**
 - Introduction.79
 - Cabling79
 - Extending the WaterRope.79
 - Cascading Water Sensors.79
 - Mounting.80
 - Configuration80
 - Sensor Template (*factory default*)81
 - Specifications.81
- IMS-4840 External Power Sensor81**
- Installation Instructions82**
 - Introduction.82
 - Package Contents.82
 - Cabling82
 - Mounting.83
 - Configuration83
 - Sensor Template (*factory default*)84
 - Specifications.84
- IMS-4841 15A High Current Sensor85**
- Installation Instructions85**
 - Introduction.85

Cabling	85
Mounting.....	86
Configuration	86
IMS-4842 20A High Current Sensor	88
Installation Instructions	88
Introduction.....	88
Cabling	88
Mounting.....	88
Configuration	89
Sensor Template (<i>factory default</i>)	89
Specifications.....	89
IMS-4850 Dry Contact Bridge.....	90
Installation Instructions	90
Introduction.....	90
Package Contents.....	90
Wiring the Contact	90
Cabling	90
Mounting.....	91
Configuration	91
Sensor Template (<i>factory default</i>)	92
Specifications.....	92
IMS-4851 4–20mA Bridge	93
Installation Instructions	93
Introduction.....	93
Package Contents.....	93
Wiring the Transducer	93
Cabling	93
Mounting.....	94
Configuration	94
Sensor Template (<i>factory default</i>)	95
Specifications.....	95
IMS-4860 Door Switch	95
Installation Instructions	96
Introduction.....	96

Package Contents 96

Mounting the Door Switch 96

Mounting the Bridge 96

Configuration 97

Sensor Template (*factory default*) 97

Specifications 98

IMS-4861 Passive Infrared Detection Sensor 99

Installation Instructions 99

Introduction 99

Package Contents 99

Configuration 100

Sensitivity Adjustment 100

Sensor Template (*factory default*) 101

Specifications 101

IMS-4862 Smoke Detector Sensor 102

Installation Instructions 102

Introduction 102

 Cabling 102

 Mounting 102

 Configuration 102

 Sensor Template (*factory default*) 103

 Specifications 103

Technical Support for the IMS-1000 Sensors 104

Appendix A: Weekly Testing Procedure 105

Appendix B: Troubleshooting 106

Appendix C: IMS-1000 Accessories 107

Appendix D: Returning an IMS Unit for Repair 108

Test Log 109

Index 111

Chapter 1: Installation

Introduction

Congratulations on your purchase of the Sensaphone IMS-1000 Infrastructure Monitoring System. The system is designed to be a comprehensive method of ensuring 100% up-time of your computer systems. By monitoring all aspects of your computer room, including environmental conditions and network equipment, the system will keep you informed of the status of your infrastructure. Monitored conditions can include temperature levels, humidity levels, line voltage, leak detection, server response, UPS systems, and more. The system allows the computer professional to be notified immediately of any detected problems. Notification can occur via voice telephone call, pager, e-mail, fax or snmp trap. An internal battery backup system insures that the unit will continue to run if main power fails.

Features

The IMS-1000 series of products includes the following key features:

- Eight sensor inputs to monitor environmental conditions and/or alarm contacts from other computer equipment such as UPS systems.
- 10/100BASE-T Ethernet port.
- Internal battery backup for uninterrupted performance.
- Compact design allows rack-mount, wall-mount, or tabletop installation.
- Embedded web page to program and manage your IMS-1000 system.

Technical Support

If any questions arise upon installation or operation of the IMS-1000, please contact the Sensaphone Technical Service Department at 610.558.2700 and have the following information available:

- Date of purchase _____
- Serial number _____

Technical support is available from 8:00 AM to 5:00 PM, eastern time.

About This Manual

This manual comprises the instructions and commands necessary to install and program the IMS-1000. Additional summary and application chapters are included to help you speed programming and to understand IMS-1000's features. You should thoroughly read this manual to establish a basic understanding of the system and keep it as a reference.

INSTALLATION and CONFIGURATION

Physical Description

The IMS-1000 is housed in a 14"w x 1.75"h x 7"d enclosure, which is 1 EIA rack-mount space high.

Front Panel Layout

The front panel contains connections for eight sensor inputs, Ethernet port, and status LEDs. See figure below:

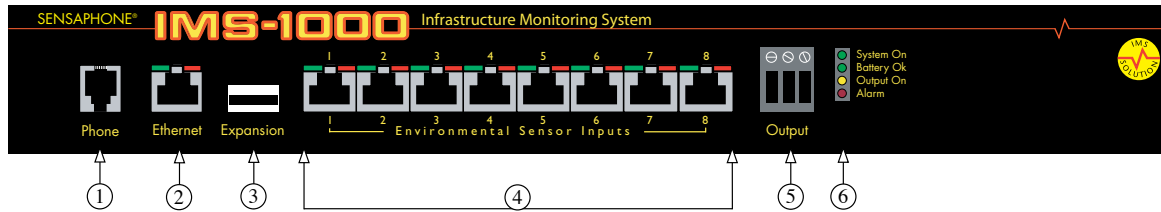

Figure 1: Front Panel Layout of the IMS-1000

- 1 Phone Line (*not present on model IMS-1001*)
- 2 Ethernet port (10/100Base-T)
- 3 USB Expansion Port
- 4 Sensor Inputs (8)
- 5 Output
- 6 LED

RJ-45 10/100BASE-T Ethernet Port

This jack is for connecting to your network so that the IMS-1000 can send e-mail, display its web page and ping selected network servers and/or services. Two LEDs indicate received data (green) and transmitted data (yellow).

Phone Jack (optional)

Connect the IMS-1000's Phone jack to a standard 2-wire analog phone line. The unit dials using touch-tones, with loop start only. The IMS-1000 will recognize ringer frequencies from 16 to 60 Hz and will operate with all standard analog telephone systems that accept tone dialing.

Certain private telephone systems and public switching equipment may not accept the unit's dialing or may generate an unacceptable ring signal. In those cases, a dedicated line may be required for the unit. Consult the supplier of your telephone system if you encounter problems.

CAUTION: Never install telephone wiring during a lightning storm. Never install telephone jacks in wet locations unless the jack is specifically designed for wet locations. Never touch uninsulated telephone wires or terminals unless the telephone line has been disconnected at the network interface. Use caution when installing or modifying telephone lines.

Sensor Inputs

The sensor inputs are designed to interface with IMS series sensors (*See Chapter 5*). The use of RJ-45 jacks for sensor inputs allows the use of existing structured cabling to connect remote sensors.

Since the sensor produces an analog signal, it must connect directly to the IMS-1000. The path from the sensor to the IMS unit CANNOT pass through a network Hub or Switch.

Sensor Input LEDs

Each sensor input has two LEDs (red and green) to indicate the present status of the input. The key below describes the multiple modes of operation.

- Mode 0: No sensor at input
 - Green: OFF
 - Red: OFF
- Mode 1: Sensor present—No alarms
 - Green: ON
 - Red: OFF
- Mode 2: Alarm detected but has not exceeded recognition time
 - Green: FAST BLINK
 - Red: OFF
- Mode 3: New alarm exists and not yet acknowledged
 - Green: SLOW BLINK
 - Red: SLOW BLINK
- Mode 4: Input is in normal range, but alarm is still unacknowledged
 - Green: ON
 - Red: SLOW BLINK
- Mode 5: Alarm has been acknowledged, but input is still out of range
 - Green: SLOW BLINK
 - Red: ON
- Mode 6: Sensor in trouble
 - Green: QUICK FLASH
 - Red: QUICK FLASH

USB Expansion Port

The USB expansion port is reserved for future IMS-1000 accessory devices. Check www.sensaphone.com or contact the Sensaphone sales department for availability.

Relay Output

The Relay Output provides a Normally Open/Normally Closed contact that can be connected to an external device (i.e. Light, siren, aux system, etc). The output can be programmed to activate when an alarm condition is detected or it may be controlled manually from the IMS-1000 web page or via touch-tone telephone. The output is rated for 1A 30VAC or 1A 24VDC.

System On LED

This light indicates that the IMS-1000 unit is powered and operational.

Battery Ok LED

This light indicates the status of the internal back-up battery. When on-steady this light indicates that the battery is charged. A flashing light means that the battery is low. When the light is off the battery is very low and is incapable of powering the unit.

Output LED

The Output LED is a visual indication that the Output Relay has been activated.

Alarm LED

The Alarm LED is a visual indication that a Power, IP Alarm, or Battery Alarm exists. When blinking this LED indicates that the alarm is un-acknowledged, a “steady-on” led indicates that the alarm is acknowledged.

Rear Panel

The rear panel is where the main power switch is located. The power adapter attaches to the connector. The unit can be powered from a 9VDC 1AMP transformer connected to 115VAC 60Hz.

ON/OFF Switch

The on/off switch connects main power and battery power to the system. Note that the system will only turn on when main power is present. When main power fails, the internal battery will automatically supply power to the unit.



Figure 2: Rear Panel of the IMS 1000

Installation

This section provides information on:

- Operating environment
- Rack, and tabletop installation
- Connecting sensors

Parts Required

Phillips
Screwdriver

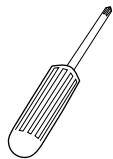

Cat 5 Network
Cable

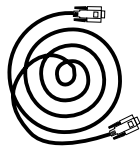

Computer



Operating Environment

Before you install the IMS-1000 be sure that your operating environment meets the physical requirements of the equipment.

- Operating Temperature: 32°–122° Fahrenheit (0°–50° C)
- Humidity: 5–90 %RH, non-condensing
- Power: 115VAC 60 Hz outlet within 6'
- Rack Requirements: Standard 19" equipment rack with supplied mounting bracket hardware. Requires 1.0 EIA rack mount space.
- Tabletop requirements: Flat area which can support an enclosure 14" wide by 7" deep by 2" high.

Rack Mount Installation

The IMS-1000 can be rack mounted using the included rack mount brackets. Follow the steps below:

- 1) Attach rack-mount brackets to the sides of the unit with a Phillips screwdriver.
- 2) Attach the unit to the equipment rack using two pan-head screws per side. Tighten the screws with a Phillips screwdriver.
- 3) Plug the power adaptor into a 115VAC 60Hz outlet.

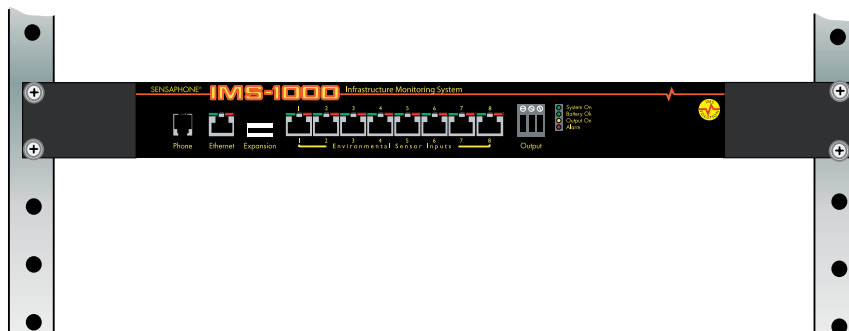

Figure 3: Rack-mounted unit

Tabletop Installation

The IMS-1000 can be installed on a tabletop or shelf. Follow the steps below:

- 1) Attach the four self-adhesive rubber feet to the four corners on the bottom of the IMS-1000.
- 2) Place the unit on a tabletop or shelf and connect the power adaptor into a 115VAC outlet.

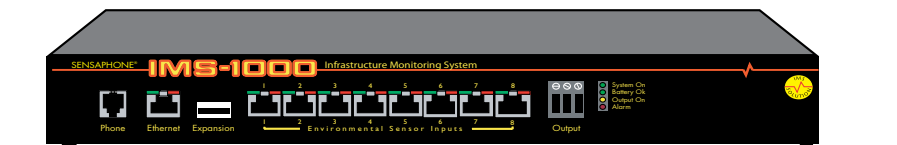

Figure 5: Tabletop-mounted unit

Power On Self Test (POST)

When the power switch is turned on, the unit will boot up and perform internal diagnostic tests. The boot and Power On Self Test take approximately three minutes.

Connecting Sensors

The IMS-1000 has eight sensor inputs. Each input can accept any sensor type. Sensors are available to monitor the following:

- Temperature
- Humidity
- Water detection
- AC voltage
- Alarm contacts from external equipment
- Smoke
- Security
- Motion
- Air Flow
- Current Draw

All IMS-1000 sensors connect to the unit using standard RJ-45 cables. This makes it easy to connect sensors directly to the unit. Simply plug one end of the cable into the sensor and the other end into one of the sensor inputs.

NOTE: Some sensors need to be opened to plug the RJ-45 cable in.

Another benefit of using RJ-45 connectors is that you can easily locate sensors at distant locations within your facility by using your existing structured cabling. For example: Suppose you have an IMS-1000 installed in room A and you want to install a sensor in room B. If your existing cabling infrastructure has an unused cable path between room A and room B, then you simply use an RJ-45 interconnect cable to connect the IMS-1000 to the patch panel in room A, and an RJ-45 interconnect cable from the wall jack in room B to the sensor.

CAUTION: The sensor produces an analog signal which *must* connect directly to the IMS-1000. The path from the sensor to the IMS unit CANNOT pass through a network Hub or Switch.

Network Configuration

The IMS-1000 is designed for installation on an Ethernet network. This involves assigning it an IP address. By default the IMS-1000 will try to acquire an IP address automatically using DHCP. If it is successful you can then use the IMS-1000 Locator program to find the IMS-1000 on your network and then assign it a fixed IP address. If no DHCP server is found the unit will fallback to a fixed IP address of 192.168.1.250. Follow the instructions below depending on which scenario applies to your network:

My network supports DHCP:

If your network supports DHCP then simply plug the network jack into the IMS-1000's Ethernet port and turn it on. Allow the unit to finish booting up (1-2 minutes). Next, install the IMS-1000 Locator program on the included CDROM (or download it from www.sensaphone.com). After installation, run the IMS-10000 Locator program and click the Search button. A list of detected IMS-1000's will be displayed showing their IP address and MAC address (IMS-1000 serial number). Click on the IMS-1000 in the list and then click Connect and your browser will open to the Login page for configuring your network settings. The default password is "ims1k". Click Login and the following page will appear:

Figure 6: Configuration

Change the DHCP Status to Disabled and enter a permanent fixed IP address. Enter the other network settings also. Consult with your network administrator if your unsure of the proper settings. Click Save when done.

My network does not support DHCP:

If your network does not support DHCP then your IMS-1000 will set its IP address to 192.168.1.250. This address should only be temporarily set. Leaving this address as the factory default could result in networking conflicts if another IMS-1000 is added to your non-DHCP supported network.

If your network does not support DHCP then you will have to use one of the following methods to change the IP of the IMS-1000 for the first time.

NOTE: It is highly recommended that you consult all network configurations and settings changes with your Network Administrator.

1) Using a standard RJ45 crossover cable connect your PC to the IMS-1000. Change the IP of your network connection to something in 192.168.1.xxx that is not the same as the default IP of the IMS-1000.

You should now be able to access the following configuration page of the IMS-1000. Point your browser at the following URL:

<http://192.168.1.250/config.asp>

Proceed to the Network Configuration section below.

2) Using a network hub connect only your PC and the IMS-1000 to the hub. Change the IP of your network connection to something in 192.168.1.xxx that is not the same as the default IP of the

IMS-1000. You should now be able to access the following configuration page of the IMS-1000. Point your browser at the following URL:

<http://192.168.1.250/config.asp>

Proceed to the Network Configuration section below.

3) Using a network switch that is configured for DHCP server connect both your IMS-1000 and your computer to the switch. Power cycle your IMS-1000. While your IMS-1000 is rebooting, configure your network connection for using DHCP. Once the IMS-1000 has rebooted it should have acquired an IP from the switch's DHCP server. Log into your switch and see what the IP the switch gave to the IMS-1000. You should now be able to access the following configuration page of the IMS-1000. Point your browser at the following URL where xxx.xxx.xxx.xxx is the IP the switch DHCP server gave your IMS-1000:

<http://xxx.xxx.xxx.xxx/config.asp>

Proceed to the Network Configuration section below. If you were unable to connect to the above URL you may need to modify the settings of the switch you are using.

Network Configuration:

The network configuration login page will be displayed. The default password is "ims1k". Click "Login" and the Network Configuration page will be loaded. Enter a static IP address for your IMS-1000 and complete the remaining network parameters. Be sure to click "Save" when done to store all the modified settings. You can now connect your IMS-1000 to your network.

Parameter Descriptions

MAC Address: This is the Media Access Control address which, in general terms, is the hardware address for the IMS-1000 Ethernet port. There is a unique address for all network devices.

DHCP Status: Enabling this option means that the IMS-1000 will automatically obtain an IP address on the network using Dynamic Host Configuration Protocol (DHCP). Disabling this option means that you will have to configure the network parameters manually.

IP/Host: This is the entry field for manually configuring the IP address of the IMS-1000 on your network. This address is provided by you or your network administrator. It is formatted as a standard dotted decimal number.

Netmask: This is the subnet mask which distinguishes the portion of the IP address that is the network ID from the portion that is the station ID.

DNS: The DNS server is used to translate site names into actual numeric network addresses. Enter the IP address of the DNS server for your network.

Gateway: A TCP/IP network must have a gateway to communicate beyond the LAN identified by the network ID. A gateway is a computer or router that is connected to two different networks and can move TCP/IP data from one to the other. If your TCP/IP network has more than one LAN or if you are connecting to the Internet, you will need to know the IP address of the gateway that will transfer TCP/IP data in and out of your LAN. A single LAN that is not connected to other LANs does not require a gateway setting.

Default Access Level: This setting determines the level of access a user will have if they open the web page without logging-in to the system. The most secure setting is “Login Required” which means a user cannot view or change anything in the system without first logging-in. There are also two read-only modes: Status-View and User-View.

Status View: The status-only user can view the current status of the system without being able to view the programming. For example, a status only user could see that an input was 75°F, but not know the calibration value (° offset) or the low/high limits for the sensor.

User View: The basic user has access to view the system without making any changes. The user shall be able to view programming without being able to change it.

The last option is to completely disable security which gives anyone full programming capability without logging-in to the system.

Configuration Password: The network configuration screen is password protected. The password can be changed by clicking the “change password” box and entering a new password in the boxes provided.

SNMP Agent Settings: The IMS-1000 contains an SNMP agent which allows read and write access to most of the IMS-1000 parameters from an SNMP console. To enable the SNMP agent click in the Enable box. You must also configure the Read-Only and Read-Write Community Strings. The default settings for these are “public” (Read-Only) and “private” (Read-Write), which are very common and should be changed for security purposes.

Battery Maintenance

The IMS-1000 includes an internal UPS that automatically switches to battery backup in the event of an AC power failure. The battery in the IMS-1000 is a 6V 3.4AH sealed lead acid. This battery will keep the unit operating for approximately 3.5 hours when fully charged and under normal operating conditions.

Service life

Over time and with periodic use, the battery will begin to lose its capacity, resulting in less overall backup time. Under normal operating conditions, three or four years of dependable service life can be expected or between 200 and 1000 charge/discharge cycles, depending on the average depth of discharge. Eventually, battery replacement will be required to maintain a dependable level of service.

Replacing the Battery

The battery can be replaced by following the instructions listed below. Be sure to read all safety messages and follow the instructions in order as listed. Several tools will be required to change the battery:

- small flathead screwdriver
- needle-nose pliers
- ¼" nut driver

CAUTION: REPLACE BATTERY ONLY WITH A 6V 3.4AH SEALED LEAD-ACID RECHARGEABLE BATTERY.

WARNING: DISCONNECT THE POWER CORD FROM THE BACK OF THE UNIT. THERE IS A RISK OF ELECTRICAL SHOCK UNLESS YOU DISCONNECT THE CORD.

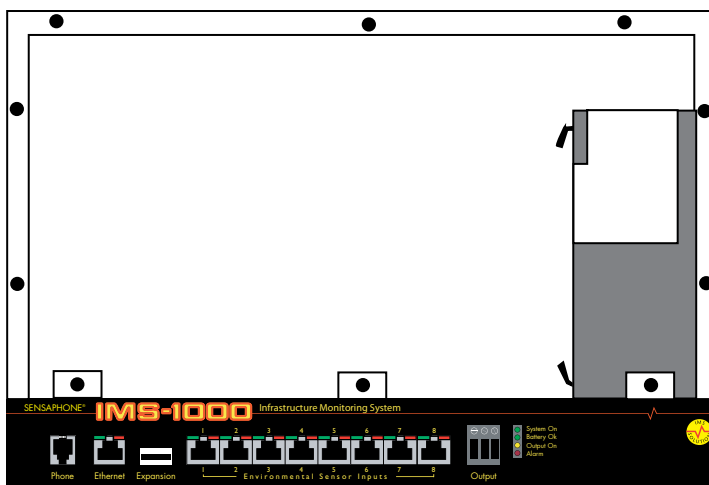

Figure 6: Battery location

- Step 1) Locate the power switch on the rear of the unit and turn the IMS-1000 off.
- Step 2) Disconnect the power cord from the back of the unit.
- Step 3) Disconnect the phone line from the front of the unit. (If present)
- Step 4) Remove the IMS-1000 from the rack.
- Step 5) Remove all of the screws in the top cover. Carefully remove the top cover.
- Step 6) Locate the battery on the right side. There will be a red wire (positive) and a black wire (negative) connected to the battery. Using needle nose pliers, remove the connector with the black wire from the battery first. Gently wiggle it off.
- Step 7) Using needle nose pliers, remove the connector with the red wire from the battery.
- Step 8) Using the nut driver, remove the two nuts which hold down the battery bracket. Remove the bracket and battery.
- Step 9) Install the new battery and replace the bracket.
- Step 10) Attach the connector with the red wire to the positive terminal of the battery.
- Step 11) Attach the connector with the black wire to the negative terminal of the battery.
- Step 12) Replace the top IMS-1000 cover and secure with the screws.
- Step 13) Re-install in rack.
- Step 14) Re-attach the power cord.
- Step 15) Re-connect the phone line. (If required)
- Step 16) Turn the Power Switch back on.

Akkumulator austauschen

Der Austausch des Akkumulators im Host verläuft gemäß den nachfolgenden Schritten. Lesen Sie alle Sicherheitshinweise aufmerksam durch und folgen Sie den Anweisungen in der angegebenen Reihenfolge. Für den Austausch des Akkumulators sind verschiedene Werkzeuge erforderlich:

- kleiner Schlitzschraubendreher
- Spitzzange
- 1/4"-Sechskantschlüssel

ACHTUNG: AKKUMULATOR NUR DURCH EINEN GELZELLENAKKUMULATOR (12 V, 2,9 AH) ERSETZEN.

WARNUNG: VOR AUSTAUSCH DAS NETZKABEL AUF DER RÜCKSEITE DES GERÄTS TRENNEN.

ANDERNFALLS BESTEHT STROMSCHLAGGEFAHR.

- Schritt 1) Das IMS-1000 mit dem Netzschalter auf der Rückseite des Geräts abschalten.
- Schritt 2) Das Netzkabel von der Rückseite des Geräts trennen.
- Schritt 3) Das Telefonkabel von der Vorderseite des Geräts trennen.
- Schritt 4) Das IMS-1000 aus dem Gestell ausbauen.
- Schritt 5) Alle Schrauben auf der Oberseite lösen. Die obere Abdeckung vorsichtig abnehmen.
- Schritt 6) Auf der rechten Seite den Akkumulator ausfindig machen. An den Akkumulator sind ein roter Leiter (+) und ein schwarzer Leiter (-) angeschlossen. Mit der Spitzzange zunächst den Anschluss des schwarzen Leiters vom Akkumulator abtrennen. Dazu den Anschluss vorsichtig mit der Spitzzange hin und her bewegen.
- Schritt 7) Mit der Spitzzange den Anschluss des roten Leiters vom Akkumulator abtrennen.
- Schritt 8) Mit dem Sechskantschlüssel die vier Muttern lösen, mit denen die Akkumulatorhalterung befestigt ist. Halterung und Akkumulator herausnehmen.
- Schritt 9) Neuen Akkumulator einsetzen und die Halterung wieder einbauen.
- Schritt 10) Den Anschluss mit dem roten Leiter am Pluspol des Akkumulators anschließen.
- Schritt 11) Den Anschluss mit dem schwarzen Leiter am Minuspol des Akkumulators anschließen.
- Schritt 12) Die obere Abdeckung des IMS-1000 wieder aufsetzen und mit den Schrauben befestigen.
- Schritt 13) Das IMS-1000 wieder in das Rack einbauen.
- Schritt 14) Das Netzkabel anschließen.
- Schritt 15) Das Telefonkabel wieder anschließen.
- Schritt 16) Den Netzschalter wieder einschalten.

IMS-1000 Specifications

Operating Specifications

Temperature	32–122°F
Humidity	5–90% RH non-condensing
Power Supply	9VDC / 1 Amp
Power Consumption (Type)	10 Watts
Power Connection	2.1mm x 10mm jack
Dimensions	1.75"h x 7"d x 14"w
Weight	lbs
Backup Battery	6V 3.4AH sealed lead acid
Backup Time	Up to 3.5 Hours

Communications Specifications

Ethernet	10/100 Base-T, 10/100Mbps
USB	Expansion port
Voice / Modem	33.6Kbps (optional)
Fax	Group 3, 14.4Kbps (Optional)

Environmental Monitoring

Internal Monitoring	AC power and battery level
Number of Sensor Ports	8
Sensor Types	Temperature, Humidity, Water, Power, Infrared Motion, Smoke, Dry Contacts
Sensor Input Connector	RJ-45
Sensor Cables	CAT-5, 568B
Cable Length	1000'
Visual Indicators	LEDs, Normal and Alarm

Chapter 2: IMS-1000 Programming

Introduction

This chapter is designed to help you program and use the IMS-1000 to its fullest potential. The IMS-1000 system helps you maintain, monitor, expedite and control the things that affect your information infrastructure.

Default Login

To login for the first time open a web browser and enter the IP address of the IMS-1000 into the address bar and hit enter. The default username is **admin** and the default password is **ims1k**.

Note: The default username and password should be deleted once an Administrator profile is configured.

Configuring the System Settings

After logging in click on the Settings button and the window below will load.



Fig. 1 Systems setting page

The following five setting categories will need to be configured:

- System • Network • Modem • Voice • Templates

System Settings

The System settings are used to describe and configure general properties of the system. The information entered into the *Name*, *Description*, and *Location* fields will appear at the top of the web page and on alarm messages sent via e-mail. Use these to help identify the facility and/or location so that when alarms occur you'll know exactly where the trouble occurred. Configure the system time by checking the *Change System Time* box and adjusting the date and time. Click *Save* when finished.

This screen also provides an entry for a *Time Server*. This can be used to periodically synchronize the system clock to keep it accurate. Simply enter the address of a time server in this field and it will automatically synchronize to it on a periodic basis. You can enter a host name or IP address in this field. The system supports NTP (Network Time Protocol), TP (Time Protocol), and DP (Daytime Protocol).

If you have the modem installed (IMS-1002) you can also assign a voice message to describe the facility and/or location of the unit. The System Voice ID is the setting that assigns one of your recorded messages as the system ID message. Voice messages must be recorded over the telephone before they can be assigned to points in the system. See *Recording Voice Messages* for details.

Network Settings

The Network Settings page allows you to view and configure various parameters related to your network.

Fig. 2 Network Settings Window

The first section, Ethernet Settings, displays the IP configuration of the IMS-1000. These parameters must be programmed on the config.asp page (see chapter 1).

The next section, SNMP Agent Status, displays the status of the SNMP agent (Simple Network Management Protocol). This can be enabled or disabled from the config.asp screen.

The SMTP (Simple Mail Transfer Protocol) section is where you must configure your e-mail server settings. To have the unit send e-mail, you need to set the SMTP Server name and the Return e-mail Address. If your SMTP servers requires authentication then check the Enable SMTP Security box and fill-in the Username and Password (if required). To specify a port number other than the standard smtp port 25, enter a colon followed by the desired port number at the end of the server name (e.g. mymailserver.com:587)

The Web Refresh Time setting allows you to select how frequently you want the information on the Summary and Channels page to automatically refresh. The minimum value for this parameter is 30 seconds.

Remote Web Page

The IMS-1000 can send a copy of its web page to another web server via FTP (File Transfer Protocol), so that the web page can be viewed on another network (for example, on the Internet). The unit can create both an html file for normal desktop viewing and also a wml file for viewing with a portable device (cell phone, pocket computer, etc...). To configure the unit to deliver a copy of the web page, fill-in the Web Page Delivery section.

Click the *Enable FTP Web Page Delivery* box and fill in the necessary information for your FTP server. Your service provider will have to provide you with the FTP Server name and sub directory where your files will be uploaded. You will also be required to enter your *username* and *password*. You can set how often you want the web page to be updated by entering an *Interval* time. Enter a *file name* for the web page (e.g. index.html). When you've finished, click *Save*. Listed below are definitions of the FTP programming parameters.

FTP Filename: This is the name of the html file that will be saved to your server.

FTP Folder: This is the directory within the server where the pages will upload.

FTP Server: This is the host name of the FTP server for your service provider.

Update Interval: This time period determines how often the web page is uploaded.

Filename for WML File: This is the filename assigned to the wml file that will be saved to your sever.

Enable FTP Security: Check this box if your FTP server requires authentication.

FTP Username: Your user name for FTP access.

FTP Password: Your password for FTP access.

Viewing the Remote Web Page

To view the remote web page that the IMS-1000 uploaded, you need to know its web address. This address corresponds to the Server name, plus the directory, plus the file name of the web page. It will look something like this:

<http://www.mycompany.com/www/index.html>

Note: Data Log and Event Log information are NOT available via the remote web page.

Modem Settings

If a modem is installed this screen will allow you to configure various parameters specific to dial-in and dial-out functions.

Fig. 3 Modem Settings

Select the *Alphanumeric Pager Speed* for your paging provider. Typically, 1200 bps will work fine with most pagers.

If your phone system does not produce a dial tone when you first lift the receiver, uncheck the box marked *Check for dial tone*. This will permit the unit to dial when no dial tone is present.

Enter the number of *Dialout Attempts* you want the IMS to make when an alarm occurs. Dialout attempts is the number of times the IMS will try to call each contact. If the unit reaches this value it will self-acknowledge the alarm and stop the dialout process for this alarm.

Enter the telephone number of the IMS-1000 in the *Unit Phone Number field*. This will appear on alarm messages delivered to numeric pagers and fax machines.

Set the *Rings Until Answer* number. This value determines how many times the line must ring before the IMS-1000 will answer.

The *Call Delay* is the amount of time the IMS will wait before making the first telephone call when an alarm occurs.

The *Intercall Time* is the time the unit waits between outgoing phone calls. During this period the unit will answer any incoming calls. To acknowledge an alarm via callback you must set this value to at least 60 seconds. When set to 0 the unit will dial back-to-back calls without the possibility of calling in to acknowledge an alarm. The Intercall Time can be set from 0–3600 seconds.

The *Voice Repetitions* value determines the number of times a spoken alarm message is repeated during an outgoing alarm telephone call.

Voice Settings

The purpose of the Voice Settings screen is to keep track of the voice messages that are recorded into each memory slot 1 - 64. This screen will let you type in the text that corresponds to each message. Voice message recording will be covered later in this chapter. It is recommended that voice message recording be performed after all environmental sensors and IP Alarms are programmed into the unit.

Template Settings

Environmental input programming Templates are used to load user specified defaults each time a new sensor is connected. By properly configuring the sensor templates before you plug in your sensors, you can minimize the amount of programming required to set up your sensors. To configure the templates, click on the sensor type on the Templates tab of the Settings page. This will bring up the individual Template programming screen for the selected sensor. An example is shown below:

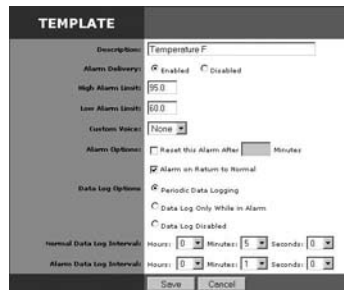

Fig. 4 Template Settings Window

Configure User Profiles and Contacts

Program the User Profiles and Contacts to control who has access to the IMS-1000 and who gets contacted when an alarm occurs. To enter a new profile click the *User Profiles* button from the main menu, then click the *Add* button. To edit an existing profile click in the box next to the profile name and click the *Edit* button. Each user must have a *Username*, *Password*, and *User Code*. You must have at least one administrator account. To set up alarm contact information fill in the fields in the contacts section. You can have up to four contacts per user. The User Profile screen is shown below:



Fig. 5: User Profile

Username: The Username is required to login to the system when security is enabled. The Username can be up to 48 characters.

Password: The Password is required to login to the system when security is enabled. The Password can be up to 48 characters.

Enable/Disable: If a profile is Disabled the user will not be able to login or access a voice status report.

User Code: The User Code is required to acknowledge alarms over the telephone or to call-in for a voice status report. The User Code must be 4 digits.

Access Level: This determines what registered Users can see and/or change when logged into the system. There are three Access Levels: Status, User, and Administrator. The Status and User levels are both read-only. The Status level can only see the Summary and Channels screens. The User level can see everything, can acknowledge alarms and switch the output but cannot make any changes. The Administrator can read or write all programming parameters.

Deleting a Profile

To delete a profile, click on the *User Profiles* button at the top of the page and select one or more profiles by clicking in the boxes next to the profile names, then click the *Delete* button.

Contacts

The Contacts are the actual telephone numbers, e-mail addresses, pager numbers, etc... that the IMS-1000 will contact when an alarm occurs. You can have up to 4 Contacts per User Profile. Only Contacts which are Enabled when the alarm occurs, will be contacted. E-mail and SNMP contacts will be sent immediately, telephone calls will be dialed in order.



Fig. 6: Contact Setup Screen

Enter a Name which describes the contact, like “Jim’s Cell,” “Acme Inc. Fax,” or “Jim at home.”

Contact String

Select the Contact Type using the drop down arrow. The choices are: Voice, Numeric Pager, Alpha Pager, Fax, Email, and SNMP.

Destination: Enter the Telephone Number, E-mail Address, or Server Name/Address for the contact.

Voice Calls

For most voice calls you can simply enter the telephone number of the person you want called. Consider the location of the IMS-1000 when entering the number. If an area code is required to call from the unit to your telephone, be sure to include it.

Examples:

no area code required: 555-1234

Area code required: (610)-555-1234

1 + area code required: 1-(610)-555-1234

You can also include additional codes within the telephone number. Listed below are the special code letters and a description of each:

p = 2-second pause

w = wait for answer

b = blind dialing (makes the unit dial and start speaking the message without requesting that a key be pressed)

! = flashes the phone line (momentary hang-up and reconnect, useful in some PBX systems)

These codes can be useful if you want to call an extension within a business. For example, suppose your office was answered by an auto-attendant, but you know that if you dialed the extension the call would be transferred. In this case you can program the telephone number, insert a w to wait for the auto-attendant to answer, and then add the extension you want dialed.

Example: 555-1234-w-170 {Extension 170 will be dialed after the auto-attendant answers}

Numeric Pager Calls

The IMS-1000 can send alarm messages to numeric pagers. It will automatically send its ID telephone number when dialing to a numeric pager. All you have to do is enter the telephone number of your pager. Be sure to include the (area code) or 1 + (area code), as necessary.

Example: (301)565-2300

If your pager service is answered by a voice-prompted message, or if your pager service allows only a few seconds to enter a number before disconnecting, you will need to enter the telephone number differently. In this case, enter the pager telephone number + two or more pauses + the IMS-1000 ID telephone number + #.

Example: (301)565-2300-pp-844-1900-#

Alphanumeric Pager / Cell Phone Text Message

The unit can send text messages to alphanumeric pagers and cell phones when an alarm occurs. The IMS-1000 uses industry standard TAP protocol, which is supported by most pager systems and cell phone carriers. The IMS-1000 will send the type of alarm, the name of the unit, the Input name, the current value, the programmed high or limit, and the time of the alarm. To program an alphanumeric-

ic pager destination, enter your service provider's TAP modem phone number followed by the letter A and then the pager ID or cell phone number.

Example: (610)555-4500-A-0504099

Contact your service provider if you do not know the data/modem telephone number or the pager ID for your alphanumeric pager.

Here are several TAP terminal telephone numbers for the major cell phone carriers:

AT&T: (866)883-7243

Cingular: (800)469-5351

Nextel: 800-201-2501

Sprint: (888)656-1727

T-Mobile: (800)506-6885

Verizon: (866)823-0501

Fax Calls

Enter the telephone number of the fax machine.

E-mail

Enter the e-mail address.

SNMP

Enter the SNMP server name or IP address.

Connect Environmental Sensors

Once you've configured the Input Templates, connect your sensors. This will automatically load the template programming for each sensor. All sensors connect to the IMS-1000 via RJ45 connectors. This allows you to use your existing structured cabling for wiring sensors throughout your infrastructure. The template programming will automatically load for each sensor as they are plugged in.

NOTE: IMS sensors are not IP devices and **cannot** connect to network Hubs or Switches.

After connecting your sensors, customize the input alarm parameters for each sensor.

Configuring Environmental Inputs

Each IMS-1000 can have up to 8 external sensors connected. The IMS-1000 will automatically identify what sensor type is connected to each input. Note that 4-20mA sensors may require additional programming to fully identify the sensor. To program the environmental input parameters click on the Channels button and select the Environmentals tab. Next, check the box next to the sensor you wish to program and click the Edit button. A sample of the channel configuration screen is shown below. Click save when you have finished entering all parameters.

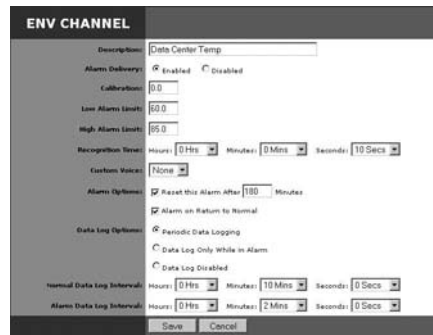

Fig. 7: Channel Configuration Screen

Description: This field is used to identify the specific sensor, sensor location, or equipment being monitored.

Alarm Delivery: This option allows you to choose whether an input will send an alarm or not when it meets the programmed alarm limit and recognition time.

Calibration: This field allows you to calibrate a sensor by adding or subtracting a small amount to your sensor readings.

Low Alarm Limit: Enter the low alarm value to trip an alarm.

High Alarm Limit: Enter the high alarm value to trip an alarm.

Recognition Time: This is the time required for a fault condition to qualify as an alarm event. The sensor/channel must remain beyond the limits or in a fault condition continuously for this entire period of time in order to become an alarm.

Custom Voice: Click the drop-down arrow and select the custom voice message you would like assigned to this sensor/channel. (Note you must record messages and label them on the *Voice Settings screen* before they will appear in this list. See *Recording Voice Messages* later in this chapter).

Alarm Reset Time: This is the time allowed for an acknowledged alarm's fault condition to be corrected before the IMS-1000 resets (reactivates) the alarm and begins the message delivery process all over again. This is an optional feature. It is recommended that this not be set any lower than 30 minutes.

Alarm on Return-to-Normal: This feature makes the unit send a message when a condition has moved within its programmed alarm limits or has gone from an alarm state to a Normal state. The person who acknowledged the alarm from a voice call and any fax, e-mail, pager, alphanumeric pager, and snmp contacts, will also receive the message.

Data Log Options: The IMS-1000 offers two modes of data logging for each channel. *Periodic Data Logging* will log the value of the input on a fixed time interval all the time. You can also choose to have the unit only log values when it exceeds the alarm limits (*Data Log While in Alarm*).

This option minimizes the amount of data collected and maximizes the storage capacity inside the unit.

Normal Data Log Interval: This is the interval that data will be logged while the input is within the programmed limits.

Alarm Data Log Interval: This is the interval that data will be logged while the input is beyond the programmed alarm limits. (Note: this is regardless of the programmed *Recognition Time*).

Environmental Input Alarm Logic

Each environmental input will automatically detect the type of sensor connected (temperature, humidity, power, motion...). Analog sensors will include high and low alarm limit programming options while two-state sensors (Normal/Alarm) will simply have a recognition time. Note that some newer sensors will require a *Sensor Type* to be manually programmed. This includes the 4–20mA Bridge, Ultra Low Temperature Sensor, the 15 Amp Current Sensor and the 20 Amp Current Sensor. The Sensor Type will appear on the Channel Edit Screen. In order for an alarm to be dispatched, the sensor must meet the following criteria:

- a) It must be Enabled for Alarm Delivery.
- b) It must have exceeded the programmed high or limit, continuously, for the duration of the Recognition Time. For two-state sensors it must be in the Alarm state, continuously, for the duration of the Recognition Time.
- c) There must be one or more (enabled) User Profiles with one or more (enabled) Contacts.

Once the alarm is dispatched, the alarm delivery process begins. (See *Alarm Delivery and Acknowledgment* for details.)

Additionally, there is an option to re-trigger the alarm if it remains beyond the High/Low limits (or in an alarm state) too long. This programmable time period is called the Alarm Reset Time. This parameter can be set from 30 to 3600 minutes.

DO NOT set the Alarm Reset Time too short, otherwise you will continue to dispatch the same alarm over and over resulting in numerous phone calls and text messages.

Trouble Alarms

The IMS-1000 monitors the presence of all connected sensors to insure the reliability of the system. When a sensor is unintentionally removed from a IMS-1000 for more than a minute, a trouble alarm is generated and messages will be sent to all contacts.

Removing/Changing a Sensor

Since the IMS-1000 monitors the presence of sensors, you must be careful when removing them to prevent a trouble alarm from occurring. The following procedure is recommended:

- a) Disable *Alarm Delivery* for the sensor you wish to change/remove.
- b) Disconnect the sensor from the IMS-1000.
- c) Select the Channels to display all of the inputs. Check the box for the sensor to be removed, check the input box and select Delete.

A new sensor can now be connected to the empty channel.

Special Notes

To reset a Smoke detector alarm, you must momentarily disconnect it from the unit, and then reconnect it. This will silence the alarm and return it to normal operating condition.

Configuring IP Alarms

IP Alarm Setup

Each IMS-1000 can monitor up to 16 IP addresses through pinging and port availability. In addition, IP dependencies can be programmed to prevent multiple alarm messages from being sent when common network paths are down.

Programming Alarm Parameters

To add an IP Alarm click on Channels from the main menu, then select the IP Alarms tab. At the bottom of the screen click Add, to make a new IP Alarm entry. A sample screen is shown below:

The screenshot shows the 'IP CHANNEL' configuration screen. It includes the following fields and options:

- IP Enabled/Disabled:** Radio buttons for Enabled (selected) and Disabled.
- Alarm Delivery:** Radio buttons for Enabled (selected) and Disabled.
- Description:** Text input field containing 'ABC Bank SMTP Server'.
- IP/Host Address:** Text input field containing 'smtp.abcbank.com'.
- Port:** Dropdown menu set to 'SMTP (25)' and a numeric input field set to '25'.
- Custom Response:** Empty text input field.
- Requires Connect Only:** Checked checkbox with note '(no custom response string necessary)'. Below it is a text input field.
- Alarm Timeout:** Numeric input field set to '10' with note '(in seconds)'. Below it is another numeric input field.
- # of Retries:** Numeric input field set to '3'.
- Time Between Attempts:** Numeric input field set to '60' with note '(in seconds, minimum of 30 seconds)'. Below it is another numeric input field.
- Dependency:** Dropdown menu set to 'ABC Bank T1 Gateway'.
- Custom Voice:** Dropdown menu set to 'None'.
- Alarm Options:**
 - Reset this Alarm After: Unchecked checkbox followed by a numeric input field and 'Minutes'.
 - Alarm on Return to Normal: Checked checkbox.
- Data Log Options:**
 - Periodic Data Logging: Unchecked radio button.
 - Data Log Only While in Alarm: Checked radio button.
 - Data Log Disabled: Unchecked radio button.
- Normal Data Log Interval:** Three dropdown menus for Hours (0), Minutes (0), and Seconds (0).
- Alarm Data Log Interval:** Three dropdown menus for Hours (0), Minutes (1), and Seconds (0).

At the bottom are 'Save' and 'Cancel' buttons.

Fig. 8: IP Alarm Setup screen

The IMS-1000 will “test” the programmed IP Address (or Domain Name) on a configurable interval. If the address fails to respond the IMS-1000 will go into alarm and notify you of the problem. A more extensive description of the logic is detailed at the end of this section. Note that for voice

calls the unit will speak the IP address if it is programmed numerically, however, if it is entered as a Domain Name you must record a custom voice message to identify the alarm. You can also record voice messages for numerically entered IP addresses, in which case the IMS-1000 will only speak the custom message. Listed below are definitions of the parameters used to configure an IP Alarm.

IP Enabled/Disabled: This setting determines whether or not the programmed IP Alarm will be tested. If it is disabled it will not be tested and will never go into alarm.

Alarm Delivery: This setting determines whether or not the IMS-1000 will send alarm messages when this IP Alarm meets the programmed alarm criteria. When set to *Disabled* you can still view the status of this IP device even though alarm messages will not be delivered.

Description: This field can be used to describe the device being monitored.

IP/Host Address: Enter the IP address or Host Name of the device you wish to monitor. Also, select the service or port you wish to test. The list includes many of the popular services. At the bottom of the list you can choose *Custom* to enter your own port number in the field to the right.

Custom Response: The IMS-1000 will check for standard responses from your IP device, but in the event that your device differs from the expected response or if you have a service that is not in the list, you can program a Custom Response. To enable the custom response field, uncheck the box titled “Requires Connect Only”.

Alarm Timeout: This is the time allowed for the IP device to respond back to the IMS-1000 when it runs its test. If the device fails to respond in the programmed time then it is considered a failure. If the number of consecutive failures exceeds the programmed number of *Retries* then a Ping Timeout alarm is tripped.

of Retries: This is the number of times the programmed IP address is tested before a Ping Timeout alarm is tripped.

Time Between Attempts: This determines how often the programmed IP address is tested. The minimum time is 30 seconds.

Dependency: This optional setting would be the IP address that must be responding for the monitored IP address to have a chance at responding. Or in other words, the monitored IP address is dependent upon the *Dependency* IP address to function.

Custom Voice: Click the drop-down arrow and select the custom voice message you would like assigned to this IP Alarm. (Note you must record messages and label them on the *Voice Settings* screen before they will appear in the list. See *Recording Voice Messages* later in this chapter).

Alarm Reset Time: This is the time allowed for an acknowledged alarm’s fault condition to be corrected before the IMS-1000 resets (reactivates) the alarm and begins the alarm message delivery process all over again. This is an optional feature. It is recommended that this not be set any lower than 30 minutes.

Alarm on Return to Normal: This feature makes the unit send a message when a failing IP Alarm begins responding again. The person who acknowledged the alarm from a voice call and all fax, e-mail, pager, alphanumeric pager and SNMP contacts will also receive the message.

Data Log Options: The IMS-1000 offers two modes of datalogging for each IP Alarm. *Periodic Data Logging* will log the status of the IP device on a fixed time interval all the time. You can also choose to have the unit only log the status when the IP device is failing (*Data Log while in Alarm*). This option minimizes the amount of data collected and maximizes the storage capacity inside the unit. Note that the minimum rate should be no less than the *Time Between Attempts*.

Normal Data Log Interval: This is the time interval that data will be logged while the IP device is responding.

Alarm Data Log Interval: This is the time interval that data will be logged while the IP device is not responding.

Alarm Logic

Network devices are monitored by the IMS-1000 by pinging/connecting to programmed IP addresses on a programmable interval. The unit will only attempt to ping/connect to devices which are *Enabled*. Each time the network device responds, the IMS-1000 updates the *Last Response* time. A time limit for responding is assigned to each IP Alarm to determine if the device is functioning properly. This time limit is called the alarm *Timeout*. If a network device does not respond within this time period, the IMS-1000 will count this as a ping failure. You can program the IMS-1000 to try to ping/connect to the network device several times before tripping an alarm. The ping *Retries* determines how many times the IMS-1000 will try to ping/connect to the device before sending an alarm. An alarm will only occur if the device fails to respond to consecutive ping attempts. Once a successful response is received, the failure counter will reset. For example: If the ping *Retries* is set to 3, then the IMS-1000 must fail to ping/connect to the device 4 times in a row (initial attempt + 3 retries) to trip an alarm. If the device were to respond after the second attempt, then the failure counter would reset, thus requiring four subsequent successive failures to trip an alarm. Once an alarm is recognized, the *Last Alarm* time will be updated.

A dependency device (IP address) can be programmed for each IP Alarm. This is used to prevent numerous alarms from occurring when common network infrastructure problems arise. If the dependency device fails, then all IP alarms that have this dependency will be temporarily disabled from sending alarms until the dependency device returns to normal (e.g. starts responding to ping/connect requests). When an IP Alarm's dependency is not responding, the status for the IP Alarm will be shown as "Route Down." It is recommended that the dependency device be programmed such that it will go into alarm before any other devices. You can achieve this by setting the number of *Retries* for the dependency device to a lower value than the IP Alarms which rely on this device.

In summary, for an IP Alarm to be dispatched, the following criteria must be met:

- a) The IP Alarm must be enabled.
- b) Alarm deliveries must be enabled.
- c) It must have failed to respond to consecutive ping/connect requests and exceed the number of retries.
- d) There must be one or more User Profiles with Contacts.

Once the alarm is dispatched, the alarm delivery process begins. The *Last Acknowledgement* time will update when the alarm has been acknowledged. In the case where there are no voice contacts, the *Last Acknowledgement* time will update immediately after the alarm occurs.

Additionally, there is an option to re-dispatch the alarm if it remains in an alarm state too long. This programmable time period is called the *Alarm Reset Time*. This parameter can be set from 30 to 3600 minutes. For example: Suppose the *Alarm Reset Time* is set to 180 minutes. Now suppose an IP device has stopped responding and trips an alarm which results in all programmed users receiving their respective messages. If the IP device continues to remain unresponsive for 180 minutes, then the alarm will be dispatched again and everyone will be contacted once more.

DO NOT set the *Alarm Reset Time* too short, otherwise you will continue to dispatch the same alarm over and over resulting in numerous phone calls, e-mails, etc.

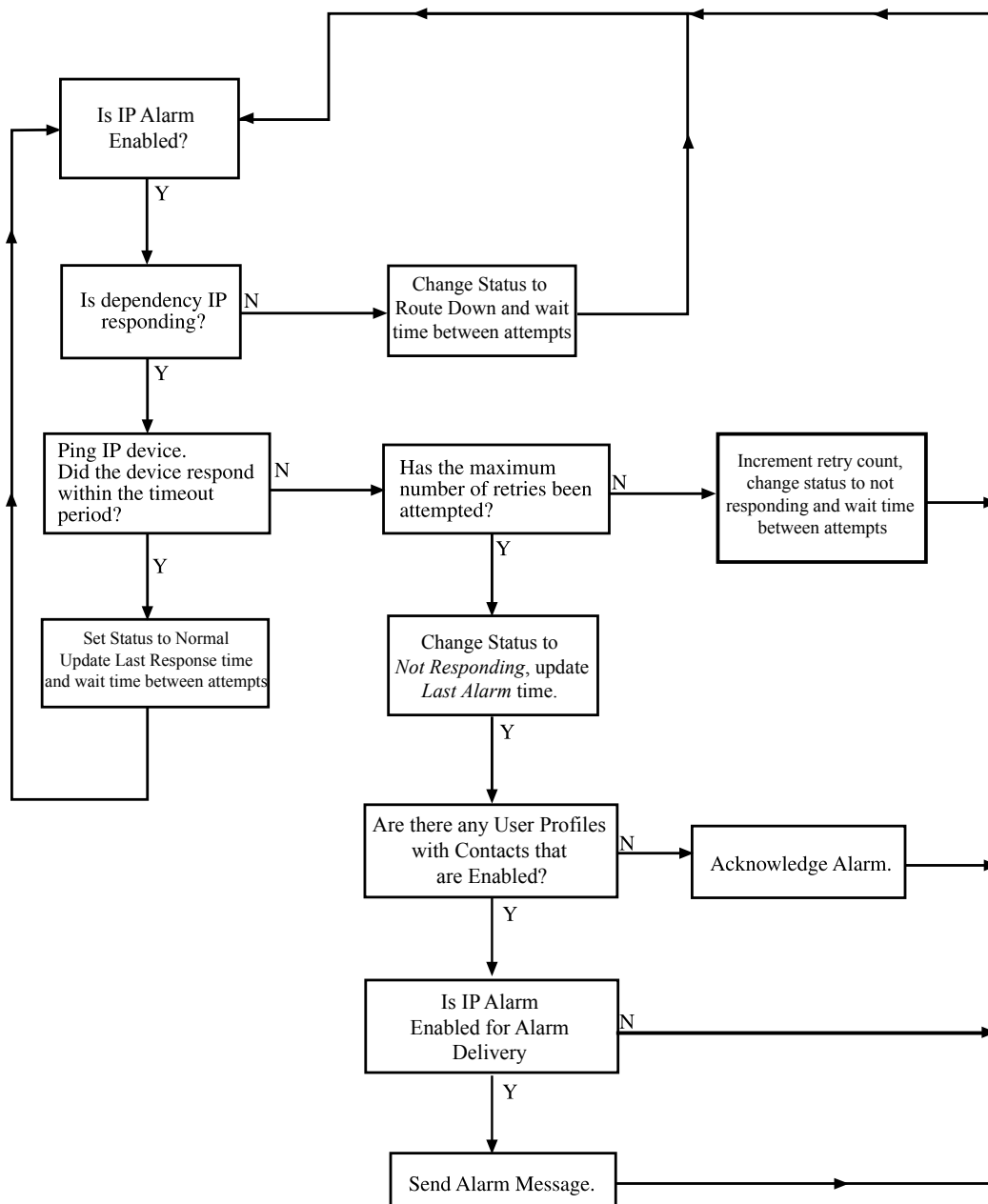

Fig. 9: IP Alarm Flowchart

Removing an IP Alarm

To remove an IP Alarm select *Channels* from the main menu, then click on the *IP Alarms* tab. Check the box next to each *IP Alarm* you wish to delete and click the *Delete* button at the bottom of the page.

Configuring a Network Video Camera

The camera setup page allows you to configure your network cameras for use with the IMS-1000. The unit can capture images from your network camera and attach them to e-mails when an alarm occurs. The IMS-1000 will also provide links on its web page for viewing a snapshot or live video from each configured camera. The IMS-1000 includes pre-configured snapshot & live video URLs for Axis, Panasonic and D-Link cameras, but you can customize the path for any manufacturers network camera using the Custom option in the Camera Type selection box. Up to 16 cameras can be used with the IMS-1000.

The first step is to get the camera running on your network. This process is independent of the IMS-1000. Follow the instructions included with the camera to get it set up on your network. Once the camera is properly set up, go into the IMS-1000 web page and click on Cameras from the main menu. Next, click the Add button at the bottom of the screen. This will bring up the Camera Setup screen (see below). Enter the information about your camera in each of the fields.



Fig. 10: Camera Setup

If you are using custom URLs you may need to contact the camera manufacturer to get the necessary information. Once you have all of the information entered, click Save and test it by clicking on the View Snapshot and View Video links on main Cameras web page. The web page can be password protected. You can program all parameters through the web page. This can be secured with the same permissions options as with the ConsoleView software. To gain access to the programming screens, you must log in on the web page.

Alarm Response via the Camera

Camera Snapshots on Alarm

Camera images may be sent to one or more users when an Environmental or IP alarm occurs. Up to four alarm responses (Camera Snapshot) may be programmed per input. To configure this feature choose the camera you want to receive an image from and click the Edit button. On the bottom half of the screen is the responses section, click Add to configure an alarm response. Select the profile and contact e-mail address, then choose the alarm to initiate the snapshot delivery.

The screenshot shows the SENSAPHONE Remote Monitoring Solutions interface. At the top, there are navigation tabs: Summary, Channels, Settings, User Profiles, and Cameras. Below these, the device information is displayed: Device: ABC Federal Savings Bank and Description: Primary Computer Room. The main section is titled 'RESPONSE' and contains the following configuration options:

- Profiles:** Jim Wilson
- Contacts:** Jim Wilson office e-mail (wilson@abcbank.com)
- Channels:** Humidity # 2 (Humidity)
- Snapshot Options:**
 - Send Continuously While in Alarm
 - Send Maximum of Snapshot(s)
- Snapshot Interval:** 1 (in seconds)
- # of Snapshots per Email:** 1
- Estimated # of Emails:** Continuous

At the bottom of the form, there are 'Save' and 'Cancel' buttons.

Fig. 11: Camera Alarm Response

There are two options to determine the *Duration* over which snapshots will be sent. If you choose *Send Continuously while in alarm* you will receive snapshots continuously until the input goes back to normal. If you choose *send maximum number of snapshots* you will receive a fixed number of snapshots once the alarm is detected. You can also select the time between snapshots in the *Snapshot Interval* field, and you can choose the number of *Snapshots Sent per E-mail*.

Note: Sending many snapshots simultaneously may use a significant amount of system memory resulting in delayed emails and/or missing snapshots. When sending simultaneous emails to multiple users you may have to minimize the number of snapshots per email or reduce the size (resolution) of the image.

Voice Recording and Assignment

Voice messages are used during call-in status reports and alarm dial-out. This allows the system to identify and describe exactly where the problem is located, which equipment is affected, or which network device is not functioning. Custom voice messages can be recorded and assigned to each environmental input and IP alarm. You can also record a message to identify your IMS-1000's location. The messages must be recorded by dialing-in to the unit using a touch-tone telephone. When you have finished speaking your message, press any touchtone to stop the recording. The voice menu will instruct you on recording and playing back each message. Once you have recorded a message, you can type in a description of each on the Voice Settings screen, then you can assign each message to the appropriate environmental input or IP alarm. Up to 30 messages can be recorded.

Note: Voice message dialout only applies to model # IMS-1002.

Step one is to make a list of all the messages you need to record. For example:

Environmental Inputs

Message 1: "Temperature in the 2nd floor data center"

Message 2: "Humidity in server room 1"

Message 3: "Phase three power failure"

..

..

Message 10: "Sensaphone battery backup"

IP Alarms

Message 11: “Company XYZ SMTP server”

Message 12: “Company XYZ web server”

Message 13: “NY office FTP server”

..

..

Message 27: “Chicago network Gateway”

Identification Message

Message 30: “The data center monitoring system in the Chicago office, 14th floor”

In this example we have grouped the environmental inputs into message numbers 1-10, the IP Alarm messages into 11-27, and the ID message into 30.

Step 2 is to call into the IMS-1000 and record your messages. When the unit answers it will ask for your User Code, then it will speak the menu below. Message recording is prompted with a beep. Press any touch-tone to end message recording.

For an Alarm Summary Report, Press 1

To listen to an Environmental Status Report, Press 2

To listen to an IP Status Report, Press 3

To play or record a voice message, Press 4

To control the relay output, press 5

To repeat this Menu , Press 0.

Step 3 is to type your message descriptions into the entry fields on the Voice Settings screen. Click Settings, then Voice from the web Page. Enter each message description, then click Save. See example below:

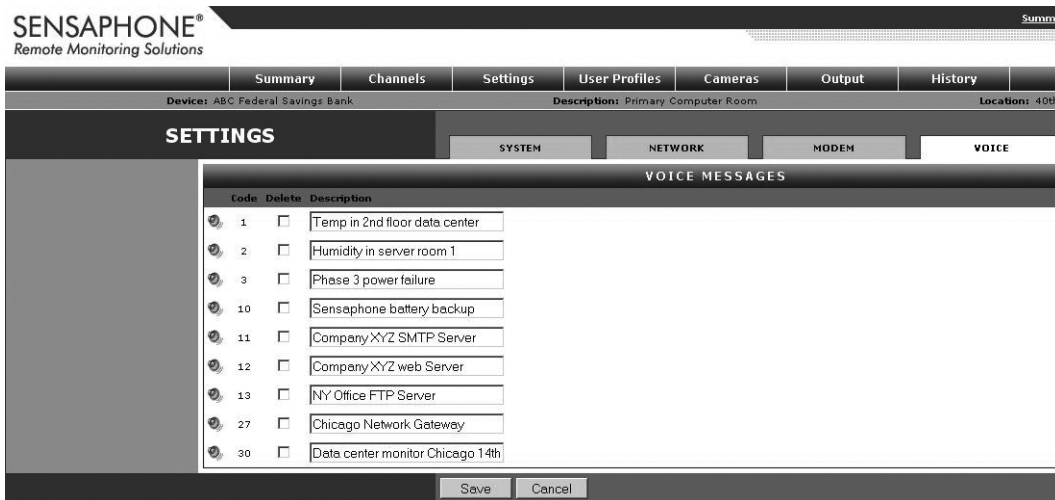

Fig. 12: Voice Settings Screen

Step 4 is to assign a voice message to each of your environmental inputs and/or IP Alarms. This is done on the channel edit screens for each input. The ID message can be assigned on the System Settings screen.

Channel View

You can get a quick summary of a particular Environmental input or IP alarm that includes Min/Max values, Last Alarm time, Last Acknowledge time, present status, most recent events, last 25 datalog records and a graph of that data. To view a summary just click on the item you wish to view from the Summary page or select an item from the Channels page and click the View button. A sample screen is shown below:



Fig. 13: Graph of AC Power

History

The IMS-1000 stores both datalog and eventlog history internally. The datalog is a time-stamped collection of input values that can be used to view and graph environmental conditions over time. It can also store the status of IP devices. The user can choose which inputs or IP alarms are stored and specify the overall sampling rate. Care should be taken to select the number of inputs and sampling rate accordingly, since large amounts of data can potentially be logged. The more data being logged, the faster the history log will fill up. The IMS-1000 can store up to 100,000 records.

The eventlog contains time-stamped messages that describe activities performed by the unit such as alarm detection, user logins, telephone calls, and alarm acknowledgement. The eventlog history is useful when you want to review the historical events monitored and performed by the IMS-1000. The eventlog can store up to 100,000 records.

Viewing History

Datalog and Eventlog history can be viewed by clicking the History button from the main page, then choose the Event log or Data log tab. Use the filters to select which channel to view, the type of records, and the time period - then click the Filter button. Depending on the size of the log this could take some time.

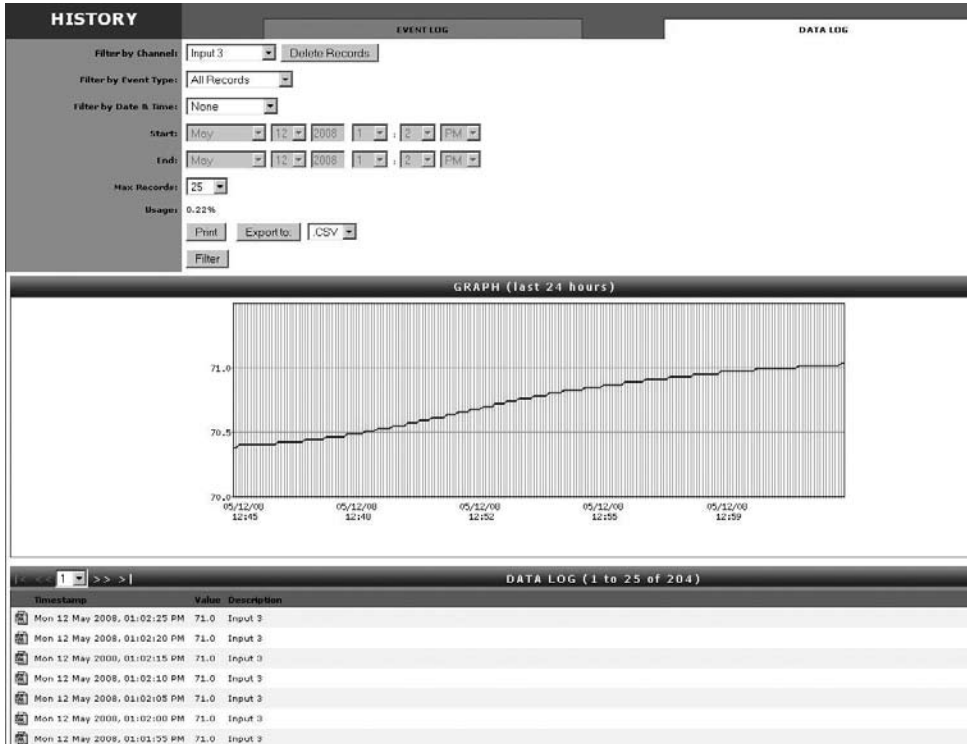

Fig. 14: History Viewer

Exporting Data

The *Export* button allows you to save the queried data to a file format which can be easily imported into other applications. Options include the ability to save the file in CSV format or XML. Note: The exported data will represent *only* what you've selected to query (e.g. Filter).

Deleting Eventlog Records

On the Eventlog tab, click the *Delete All Records* button. This will delete all eventlog records in the IMS-1000.

Deleting Datalog Records

On the Datalog tab, select a single input or choose all channels and click the *Delete Records* button. This will delete the selected datalog records.

SMTP Error messages

If your e-mail settings are incomplete or incorrect there are some messages that will appear in the Event History log which may be helpful.

The “Invalid Configuration” message will appear if you don’t have both the SMTP Server name and Return Address programmed. These are the minimum programming requirements to send e-mail. If you have at least these two items programmed and the IMS-1000 is unable to deliver the message, then you may have one or more of the following problems:

- (a) The wrong SMTP server name programmed.
- (b) The wrong username programmed.
- (c) The wrong password programmed.
- (d) A username is programmed but none is required.
- (e) A password is programmed but none is required.
- (f) All of the e-mail settings are programmed properly but the unit cannot reach your SMTP server for network routing reasons.
- (g) The unit cannot reach your DNS server and thus cannot look up the SMTP server IP address.
- (h) The DNS server IP address is programmed incorrectly in the IMS Network Configuration settings.

Saving and Loading Programming

The programming in your IMS-1000 can be saved to a file. This gives you the ability to back up your programming or copy the same programming to another IMS-1000 unit. Note that the file you save will not include parameters from the Network Configuration page. It will, however, contain any custom voice messages that you may have recorded. To save your programming to a file, go to the Config.asp page. Click the Advanced tab, then click the Download button.

To Load a programming file into your IMS-1000, click the Browse button to locate your IMS-1000 programming file. Next, click the Upload button. Select *Load Programming*. Select a programming file to load and click the *Load* button. Your unit will have to restart for the new programming to take effect. When the unit restarts, you will be logged off. Wait one minute, then reconnect to the unit.

Updating Firmware

From time to time Firmware updates will become available to add features or improve the performance of your IMS-1000. Most Firmware updates will be included as part of a complete IMS-1000 installation upgrade. Check the IMS-1000 website (www.sensaphone.com/support-1000.html) for the latest information on updates. To install new firmware or to check the version of firmware in your unit, go to the Config.asp page, then click the Advanced tab.

Resetting to Factory Defaults

In the event that you are unable to log-in to your IMS-1000 because you have forgotten your username and/or password, or if you just want to reset your unit to factory new, the procedure below will delete all of your programming, history and network settings, resulting in a factory new device:

- 1) Turn the Power switch OFF.
- 2) Disconnect the power, Ethernet & telephone cables.
- 3) Remove the 8 screws on the cover and set the lid aside.

- 4) Locate the jumper in the center of the circuit board that says “Normal Operation” and “Factory Defaults”. Move the jumper to the Factory Defaults position. Temporarily place the lid on the unit and connect the power cable. Turn the power switch on for 2 minutes.
- 5) Turn the power switch OFF and disconnect the power cable. Remove the lid. Move the Jumper back to the “Normal Operation” position. Reassemble the lid with the 8 screws. The unit is now reset.

Configuring the Relay Output

The IMS-1000 includes a relay output that can be used to control a light, siren, or other low voltage device. The output is a Form-C Normally Open/Normally Closed mechanical relay and is rated for 1A 30VAC or 1A 24VDC. A sample wiring diagram is shown below:

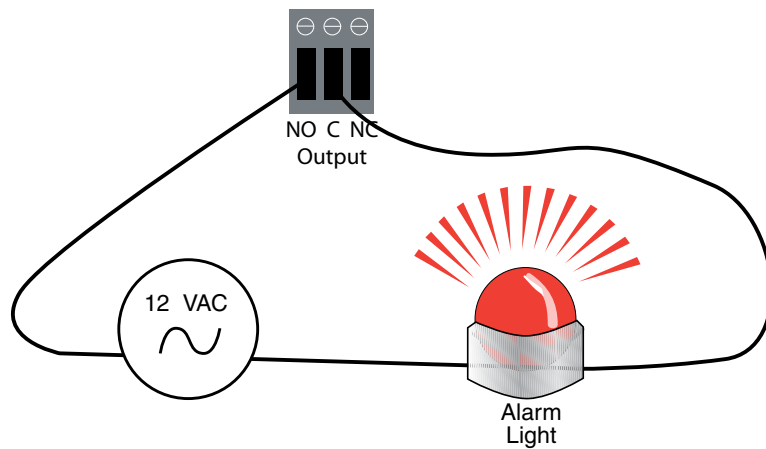

The output connector is located on the front of the unit and is labeled “Output”. When connecting wires to the output terminal block be sure to strip a 1/2 ” of wire insulation before inserting the wire (see figure below):



The output has three terminals labeled NO (Normally Open), C (Common), and NC (Normally Closed). The three terminals make a single-pole, double-throw switch. The diagram below shows how the terminals connect internally when the output is OFF. When the output is turned ON the C contact switches from the NC position to the NO position.

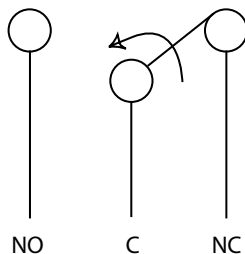

Modes of Operation

The output can be programmed to operate in either manual mode or one of two automatic modes (Alarm Condition or Unacknowledged Alarm). The different operating modes are described below:

Manual Mode: The output can be operated by using the IMS-1000 Web Page or via touch-tone command during a voice call-in.

Automatic Modes

Alarm Condition: The output will turn ON when any of the selected environmental sensors or IP alarms are in alarm, regardless of acknowledgement. The output will turn off when the alarm condition returns to normal status. (Note: The alarm must be enabled and the alarm recognition time must have expired).

Unacknowledged Alarm: The output will turn on when any of the selected inputs has an unacknowledged alarm. Once the alarm is acknowledged the output will turn off. (Note: The alarm must be enabled and the alarm recognition time must have expired).

Setting the Output Mode

To program the Output Mode, click on the Output button from the main menu, then click Edit. The following screen will appear:

The screenshot shows the SENSAPHONE Remote Monitoring Solutions web interface. The page is titled "OUTPUT" and is part of a configuration menu. The navigation menu includes Summary, Channels, Settings, User Profiles, Cameras, and Output. The current page is "Output" for the device "USA Widget Manufacturing" with the description "Environmental Monitor".

The "Output Mode" section has three radio buttons: Manual, Automatic, and Unacknowledged Alarm. The "Alarm Condition" radio button is selected. Below this is an "Activation List" section with the instruction "(check channels to activate)".

The "CHANNELS" table lists various sensors and alarms with checkboxes for activation:

Name	Type
<input checked="" type="checkbox"/> UPS Battery Alarm	Normally Open
<input checked="" type="checkbox"/> Data Center Humidity	Humidity
<input checked="" type="checkbox"/> Data Center Temperature - Front	Temperature F
<input checked="" type="checkbox"/> Data Center Temperature - Rear	Temperature F
<input checked="" type="checkbox"/> Phase B Power	External Power
<input type="checkbox"/> Closet #2 Infrared Detector	Infrared Motion
<input type="checkbox"/> Data Center Smoke Alarm	Smoke Detector
<input checked="" type="checkbox"/> Power	Internal Power
<input type="checkbox"/> Battery	Internal Battery
<input type="checkbox"/> Widgets Web Page (10.1.2.47:80)	IP Alarm
<input type="checkbox"/> SMTP Server (10.1.2.111:25)	IP Alarm
<input type="checkbox"/> POP3 server (216.117.145.170:110)	IP Alarm
<input type="checkbox"/> FTP Server (64.191.17.13:21)	IP Alarm
<input type="checkbox"/> Oracle Server (10.1.2.112)	IP Alarm
<input type="checkbox"/> SAP Server (10.1.2.201)	IP Alarm
<input type="checkbox"/> Widgets Firewall (10.1.2.113)	IP Alarm

At the bottom of the page are "Save" and "Cancel" buttons.

Manual Output Mode

To select Manual Mode click the circle labeled Manual then click Save. In this mode you can click the Turn On or Turn Off button at the top of the screen to activate/deactivate the output. For control using a touch-tone telephone see section titled "Touch-Tone Control".

Alarm Condition and Unacknowledged Alarm Mode

To select one of these modes click the circle labeled Automatic from within the Output Mode section of the screen. Next, click the circle for either Alarm Condition or Unacknowledged Alarm. Next, select the Environmental Inputs and/or IP Alarms that you would like to have control the output.

Touch-Tone Control

If the output is set to Manual mode you can control it using touch-tone commands over the telephone. To do this call the unit and enter your User Code when prompted. The unit will begin speaking and will eventually provide various menu options. Select option 5 to control the relay output. Follow the prompts to turn the relay output ON or OFF. The unit will respond “on” or “off” to indicate that the command was executed successfully.

Chapter 3: Operation

After installation and programming have been completed, the Sensaphone IMS-1000 is fully operational. This chapter explains how the IMS-1000 operates.

Alarm Delivery and Acknowledgment

The IMS-1000 will start with the first profile and attempt to send an alarm message to each contact. The 1000 will then proceed to the next User Profile. All e-mail, fax, snmp, alphanumeric and numeric pager contacts will be sent the alarm message. Voice contacts will be called until the alarm is acknowledged. Once the alarm is acknowledged any remaining voice contacts will not be called. With this in mind it is important that you organize your user profiles accordingly.

Alarm Acknowledgment

Alarms can be acknowledged five ways:

- 1) By entering your *Usercode* using a touch-tone telephone when prompted during a Voice telephone call.
- 2) By calling in to the unit and entering your *Usercode* via touch-tone phone when prompted. Note that the *Intercall Delay* must be set to a minute or more to allow time to call in to the unit.
- 3) By logging-in to the IMS-1000 and clicking the *Alarm Acknowledgment* button on the Channels screen for the Input in alarm. See sample below:

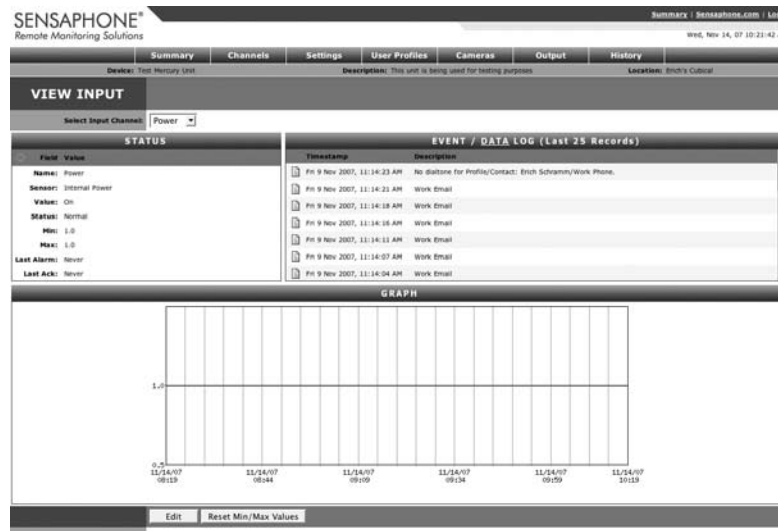

Figure 1: Alarm Acknowledgment button

- 4) If the unit has no voice calls to make it will self-acknowledge the alarm after all other forms of alarm delivery have been completed.
- 5) If the maximum number of calls are attempted the unit will self-acknowledge the alarm.

Sample Alarm Messages

Sample E-mail alarm message

From: IMS1000@Sensaphone.com
To: jwilson@abcbank.com
Date: Mon, Jan 7, 2008 at 5:18 PM
Subject: Alarm Notification from ABC Federal Savings Bank

Alarm notification for Humidity - Server Room #2.
Low Humidity ALARM at ABC Federal Savings Bank
Humidity - Server Room #2 is now 23.6 %RH
Level crossed limit of 25.0 %RH
on Monday 7 January 2008, 05:18:00 PM

Sample Fax message

***** IMS-1000 ALARM REPORT *****

TO: John Smith
CIO
ABC Widgets Inc.
Information Technology

FAX NUMBER: 7779992233

FROM: ABC Widgets Inc.
IMS-1000
Boston, MA

PHONE NUMBER: 7779992000

ALARM MESSAGE:

High temperature ALARM at ABC Widgets Inc.
CH1: Server room temperature is now 90.3 Deg F
Level crossed limit of 85.0 Deg F
on Thursday 28 March 2002, 10:24:32 AM EST

Sample Alphanumeric Pager Message

Alarm notification for Rack #7 Temperature.
High Temperature ALARM at ABC Federal Savings Bank
Rack #7 Temperature is now 86.5 Deg F
Level crossed limit of 85.0 Deg F
on Tuesday 22 April 2008, 08:41:21 AM

Voice Status Report and Touch-Tone Commands

The IMS-1000 is capable of delivering a spoken status report when called via telephone. The status report can provide information on both environmental conditions and IP alarms.

Sample Status Report

To receive a status report, call the unit. The unit will answer and begin speaking and request your *User Code*. If the unit receives a valid User Code it will continue with several menu options. A sample of the main menu is shown below:

Hello, this is the IMS-1000 - "this the ABC Federal Savings Bank at 1040 Chestnut Street"
(custom voice message)

Enter your User code. {valid code is received}

No alarms exist.

For an Alarm Summary Report, Press 1

To listen to an Environmental Status Report, press 2.

To listen to an IP status report, Press 3.

To play or record a voice message, Press 4.

To control the Relay Output, Press 5.

To repeat this menu, Press 0.

If the caller had selected option 1 they would hear an environmental status report. The alarm summary only reports on inputs and IP alarms that are currently beyond their limits, or are in an alarm condition. A sample of an environmental status report is listed below. Items in italics are custom messages recorded by the user.

Channel 1, *temperature in the server room*, is 76.4 degrees Fahrenheit, normal

Channel 2, *temperature in rack B*, is 82.7 degrees Fahrenheit, too high

Channel 3, *humidity in the server room*, is 33.9%, normal

Channel 6, *water under server room floor*, normal

Channel 7, *smoke alarm in the server room*, normal

The power is ON

The battery is 100%, normal

Voice Alarm Dialout

The IMS-1000 can call and deliver an alarm message in spoken English. After dialing, the unit will begin speaking "IMS-1000 Alarm Message, Press any key to continue." If the unit receives a touch-tone, it will recite the alarm message. When it finishes speaking the message it will request acknowledgement. A sample Voice Alarm call is shown below:

"Sensaphone Alarm Message, press any key to continue"

"Sensaphone Alarm Message, press any key to continue" {call is answered and a 5 is pressed}

"IMS-1000 Alarm Message. The temperature is High *at the IT Dept of XYZ Company.*"

"Channel 1, *temperature in the server room*, is 81.5 Degrees Fahrenheit"

"Level crossed limit of 80 Degrees Fahrenheit at 7:45PM."

"To repeat press *"

“Enter User Code to acknowledge:” {valid User Code is received}

“Alarm Acknowledged. ” {main menu}

Call-in Alarm Acknowledgment

If you receive an alarm message on your pager or in your voice mail, you can still acknowledge the alarm by calling the unit back and entering your User Code. Note that the Intercall Delay must be set to at least 1 minute in order for the unit to answer a call.

When you call in to the unit, wait for the beep and then press a button on your touch-tone telephone. If there are unacknowledged alarms, the unit will say “Unacknowledged alarms exist”. Then listen to the following menu and choose the appropriate option. When the unit finishes announcing all of the alarms, it will say “Enter your user code.” If the user code is entered correctly the unit will say “Alarm acknowledged” and it will acknowledge all of the alarms announced, and stop dialing all voice contacts.

Chapter 4: SNMP (Simple Network Management Protocol)

The IMS-1000 contains an SNMP agent that supports versions (v1 and V2c), over both UDP and TCP transports. Read and write access to most of the IMS-1000 parameters is provided along with the ability to send traps when alarms occur. A complete SNMPv1 MIB is provided on the IMS-1000 CD.

The SNMP agent can be enabled or disabled from the network settings screen. The SNMP community strings are also configured on this page. See Chapter 1 for details.

Through the SNMP protocol, most of the programming parameters and status information can be accessed. The following is a summary of the IMS-1000 items that can be fully accessed through SNMP:

- Edit Environmental input programming
- Edit IP Alarm programming
- Edit System programming (unit info, e-mail setup, Web FTP setup, phone settings)
- Enable/Disable Datalogging
- Edit the Datalog interval
- Edit Environmental input template programming
- Edit Camera setup
- Acknowledge alarms
- View Network and Security configuration parameters

Some parameters of the IMS-1000 involve complex data structures and cannot be accessed through the SNMP protocol. The following operations *cannot* be performed through SNMP:

- Add or delete IP alarms
- Add or delete Profiles or Contacts
- Delete a sensor
- Configure the system clock
- Edit alarm response programming sequences

The various values that can be retrieved from an MIB are called *MIB variables*. Each MIB variable is named by an Object Identifier (OID), which usually has a name in the form of numbers separated by periods (“.”), like this: .1.3.6.1.x.x.xxxx.x.x.x.x... OIDs for all MIB variables can be determined by browsing the MIB.

Below are some examples of the more common OIDs in the IMS-1000:

Name: .iso.org.dod.internet.private.enterprises.sensaphone

Sensaphone OID: .1.3.6.1.4.1.8338

Environmental Input Values: 1.1.3.1.6.1.1.42 (input number) .0

Example: environmental input #3: .1.3.6.1.4.1.8338.1.1.3.1.6.1.1.4.2.3.0

Chapter 5: IMS-1000 Sensors

IMS-4810 Room Temperature Sensor

Installation Instructions

Introduction

The IMS-4810 temperature sensor is designed to connect to the IMS-1000 and monitor indoor temperatures. The electrical connection between the sensor and IMS-1000 is made via RJ-45 patch cable (not included). The sensor may be mounted either on a wall or to a single-gang electrical box.

Package Contents

- (1) IMS-4810 Temperature sensor
- (2) Plastic drywall anchors
- (2) #6 Metal tapping screws
- (1) 1/6" hex key



Cabling

The temperature sensor connects to the IMS-1000 via an RJ-45 cable (e.g. CAT5 cable). The connection from the sensor to the IMS-1000 can utilize your existing network wiring infrastructure. For example, the sensor may be installed in another room or another floor. Connect the sensor to your structured wiring network via an RJ-45 jack. At the other end, connect a patch cable from your structured wiring patch panel directly to the IMS-1000 environment input.



Caution: The IMS sensors are not TCP/IP devices and therefore should not be connected directly to any wiring infrastructure that is connected to network equipment such as a hub, router, or switch. Sensors use RJ-45 plugs and cables similar to those used with Ethernet devices.

Mounting

The temperature sensor can be mounted directly on a surface or attached to a single-gang electrical box. Consideration should be given to cable routing before attaching the sensor to the wall. Will the cable go through the wall (cable hidden) or will it run down the wall (cable visible)? Once this has been determined, run the cable to the location where the sensor will be installed.

Electrical box installation

Bring the RJ-45 cable through the electrical box. Remove the sensor cover by turning the two hex screws on the bottom of the sensor housing clockwise. Bring the cable through the back of the sensor and connect the cable to the jack as shown in Figure 1. Attach the sensor to the electrical box using the appropriate screws. Secure the sensor cover by turning the two hex screws on the bottom of the cover counterclockwise.

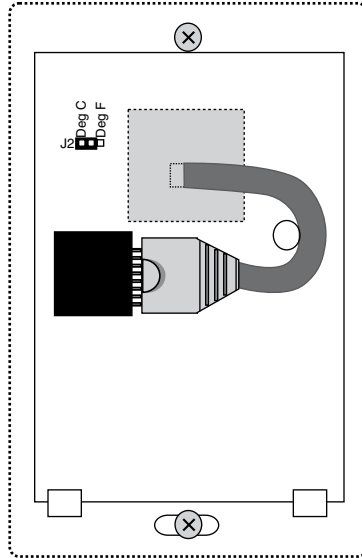

Figure 1: 4810 with Cable exiting through back of enclosure

Hidden cable surface installation

Bring the RJ-45 cable through the wall at the mounting location. Remove the sensor cover by turning the two hex screws on the bottom of the sensor housing clockwise. Bring the cable through the back of the sensor and hold the sensor housing against the wall. Use a pencil to mark the hole locations at the top and bottom of the housing. Remove the sensor from the wall. Install the drywall anchors (if necessary) to the wall. Bring the cable through the back of the sensor and connect it to the jack as shown in Figure 1. Attach the sensor to the wall using #6 tapping screws. Secure the sensor cover by turning the two hex screws on the bottom of the cover counterclockwise.

Visible cable surface installation

Remove the sensor cover by turning the two hex screws on the bottom of the sensor housing clockwise. Hold the sensor housing against the wall. Use a pencil to mark the hole locations at the top and bottom of the housing. Install the drywall anchors (if necessary) to the wall. Attach the sensor to the wall using #6 tapping screws. Connect the cable to the jack as shown in Figure 2. Secure the sensor cover by turning the two hex screws on the bottom of the cover counterclockwise.

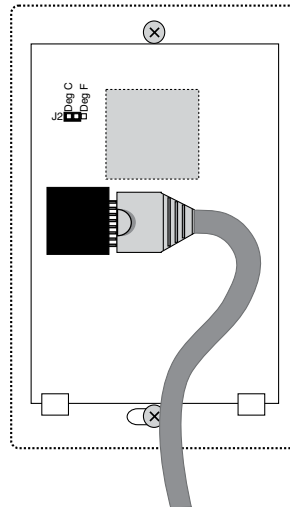

Figure 2: 4810 with Cable exiting out enclosure bottom

Configuration

All IMS Solution sensors are auto-configured when you plug them into the IMS-1000. When a new sensor is plugged into the IMS-1000, the configuration is set to the factory default via the *Sensor Template*. If you have modified these templates, the configuration will be set to the modified configuration. When a sensor is removed, or the connection is disrupted, the configuration data remains intact but the sensor will go into trouble status and generate a trouble alarm. When the sensor is plugged in again, or the connection is re-established, configuration data remains unchanged and the sensor returns to normal operating condition.



Caution: Removing a sensor for less than 60 seconds does not produce a trouble alarm. Removing or unplugging a sensor for more than 60 seconds or plugging in a different sensor at any time will cause a trouble alarm.

Fahrenheit/Celsius Selection

The IMS-4810 can provide temperature readings in either degrees Fahrenheit or Celsius. To select one or the other, remove the sensor cover by turning the two hex screws on the bottom of the sensor housing clockwise. Locate the black jumper (see Figure 3) marked J2. Install the jumper in the “Deg F” position for Fahrenheit or the “Deg C” position for Celsius. Secure the sensor cover by turning the two hex screws on the bottom of the cover counterclockwise.

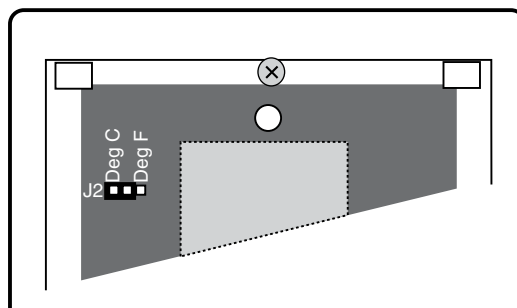

Figure 3: Jumper location (set for Degrees Celsius)

Sensor Template (*factory default*)

Input Name: Temperature
Low Temperature Limit: 50° F
High Temperature Limit: 85° F
Recognition Time: 60 Seconds
Reset Time: 0 Seconds
Data Logging: Active
Voice: temperature.wav
Input Class: Temperature

Specifications

Range: 5–122 degrees F (-15 to 50 degrees C)
Humidity: 5–90 %RH
Sensor type: solid state ic
Accuracy: +/- 3 degrees F
Connector: RJ-45
Housing: white plastic

IMS-4811 Room Temperature Sensor with display (Fahrenheit)

Installation Instructions

Introduction

The IMS-4811 temperature sensor is designed to connect to the IMS-1000 and monitor indoor temperatures. The electrical connection between the sensor and IMS-1000 is made via RJ-45 patch cable (not included). The sensor may be mounted either on a wall or to a single-gang electrical box.

Package Contents

- (1) IMS-4811 Temperature sensor
- (2) Plastic drywall anchors
- (2) #6 Metal tapping screws
- (1) 1/16" hex key



Cabling

The temperature sensor connects to the IMS-1000 via an RJ-45 cable (e.g. CAT5 cable). The connection from the sensor to the IMS-1000 can utilize your existing network wiring infrastructure. For example, the sensor may be installed in another room or another floor. Connect the sensor to your structured wiring network via an RJ-45 jack. At the other end, connect a patch cable from your structured wiring patch panel directly to the IMS-1000 environment input.



Caution: The IMS sensors are not TCP/IP devices and therefore should not be connected directly to any wiring infrastructure that is connected to network equipment such as a hub, router, or switch. Sensors use RJ-45 plugs and cables similar to those used with Ethernet devices.

Mounting

The temperature sensor can be mounted directly on a surface or attached to a single-gang electrical box. Consideration should be given to cable routing before attaching the sensor to the wall. Will the cable go through the wall (cable hidden) or will it run down the wall (cable visible)? Once this has been determined, run the cable to the location where the sensor will be installed.

Electrical box installation

Bring the RJ-45 cable through the electrical box. Remove the sensor cover by turning the two hex screws on the bottom of the sensor housing clockwise. Bring the cable through the back of the sensor and connect the cable to the jack as shown in Figure 1. Attach the sensor to the electrical box using the appropriate screws. Secure the sensor cover by turning the two hex screws on the bottom of the cover counterclockwise.

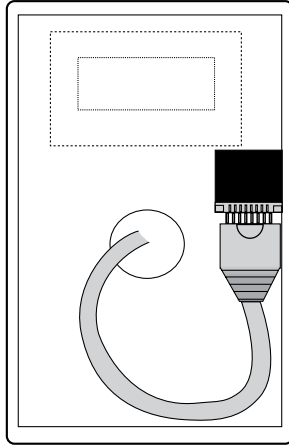

Figure 1: 4811 with Cable exiting through back of enclosure

Hidden cable surface installation

Bring the RJ-45 cable through the wall at the mounting location. Remove the sensor cover by turning the two hex screws on the bottom of the sensor housing clockwise. Bring the cable through the back of the sensor and hold the sensor housing against the wall. Use a pencil to mark the hole locations at the top and bottom of the housing. Remove the sensor from the wall. Install the drywall anchors (if necessary) to the wall. Bring the cable through the back of the sensor and connect it to the jack as shown in Figure 1. Attach the sensor to the wall using #6 tapping screws. Secure the sensor cover by turning the two hex screws on the bottom of the cover counterclockwise.

Visible cable surface installation

Remove the sensor cover by turning the two hex screws on the bottom of the sensor housing clockwise. Hold the sensor housing against the wall. Use a pencil to mark the hole locations at the top and bottom of the housing. Install the drywall anchors (if necessary) to the wall. Attach the sensor to the wall using #6 tapping screws. Connect the cable to the jack as shown in Figure 2. Secure the sensor cover by turning the two hex screws on the bottom of the cover counterclockwise.

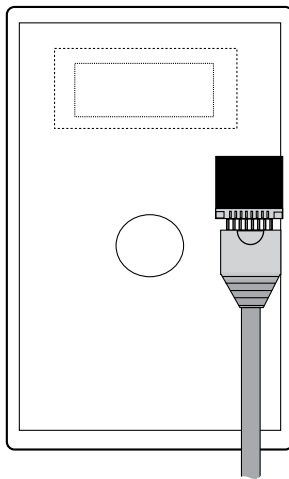

Figure 2: 4811 with Cable exiting out enclosure bottom

Configuration

All IMS Solution sensors are auto-configured when you plug them into the IMS-1000. When a new sensor is plugged into the IMS-1000, the configuration is set to the factory default via the *Sensor Template*. If you have modified these templates, the configuration will be set to the modified configuration. When a sensor is removed, or the connection is disrupted, the configuration data remains intact but the sensor will go into trouble status and generate a trouble alarm. When the sensor is plugged in again, or the connection is re-established, configuration data remains unchanged and the sensor returns to normal operating condition.



Caution: Removing a sensor for less than 60 seconds does not produce a trouble alarm. Removing or unplugging a sensor for more than 60 seconds or plugging in a different sensor at any time will cause a trouble alarm.

Sensor Template (*factory default*)

Input Name:	Temperature
Low Temperature Limit:	50° F
High Temperature Limit:	85° F
Recognition Time:	60 Seconds
Reset Time:	0 Seconds
Data Logging:	Active
Voice:	temperature.wav
Input Class:	Temperature

Specifications

Range:	32–95 degrees F
Humidity:	5–90 %RH
Sensor type:	solid state ic
Accuracy:	+/- 3 degrees F
Connector:	RJ-45
Housing:	white plastic

IMS-4812 Mini-Temperature Sensor (Fahrenheit)

Installation Instructions

Introduction

The IMS-4812 Mini Temperature Sensor is designed to connect to the IMS-1000 and monitor temperatures in tight locations (for example, inside equipment racks). The electrical connection between the sensor and IMS-1000 is made via the attached RJ-45 patch cable. The sensor may be secured inside equipment using double-sided tape (included) or with tie-wraps.



Cabling

The Mini-Temperature Sensor comes with an attached 7' cable with an RJ-45 plug on the end. If the sensor is close to the IMS-1000, you can plug the sensor directly to an IMS environmental input. If the cable is too short you can use the included RJ-45 adaptor and a longer patch cable to extend the length. For applications where the sensor may be far from the IMS unit, you may utilize your existing network wiring infrastructure. For example, the sensor may be installed in another room or another floor. Connect the sensor to your structured wiring network via an RJ-45 jack. At the other end, connect a patch cable from your structured wiring patch panel directly to the IMS-1000 environment input.

Caution: The IMS sensors are not TCP/IP devices and therefore should not be connected directly to any wiring infrastructure that is connected to network equipment as a hub, router, or switch. Sensors use RJ-45 plugs and cables similar to those used with Ethernet devices.

Mounting

The temperature sensor may be mounted directly on a surface using double-sided tape (included) or it may be secured to equipment using tie-wraps. The choice depends on your application.

Configuration

All IMS Solution sensors are auto-configured when you plug them into the IMS-1000. When a new sensor is plugged into the IMS-1000, the configuration is set to the factory default via the *Sensor Template*. If you have modified these templates, the configuration will be set to the modified configuration. When a sensor is removed, or the connection is disrupted, the configuration data remains intact but the sensor will go into trouble status and generate a trouble alarm. When the sensor is plugged in again, or the connection is re-established, configuration data remains unchanged and the sensor returns to normal operating condition.



Caution: Removing a sensor for less than 60 seconds does not produce a trouble alarm. Removing or unplugging a sensor for more than 60 seconds or plugging in a different sensor at any time will cause a trouble alarm.

Sensor Template (*factory default*)

Input Name: Temperature
Low Temperature Limit: 50° F
High Temperature Limit: 85° F
Recognition Time: 60 Seconds
Reset Time: 0 Seconds
Data Logging: Active
Voice: temperature.wav
Input Class: Temperature

Specifications

Range: 5–140 degrees F
Humidity: 5–90% RH
Sensor type: solid state ic
Accuracy: +/- 3 degrees F
Connector: 7' cable w/RJ-45 plug
Housing: black plastic
Housing dimensions: 2.13" l x 0.6" d x 1.38" h

IMS-4813 Room Temperature Sensor with display (Celsius)

Installation Instructions

Introduction

The IMS-4813 temperature sensor is designed to connect to the IMS-1000 and monitor indoor temperatures. The electrical connection between the sensor and IMS-1000 is made via RJ-45 patch cable (not included). The sensor may be mounted either on a wall or to a single-gang electrical box.

Package Contents

- (1) IMS-4813 Temperature sensor
- (2) Plastic drywall anchors
- (2) #6 Metal tapping screws
- (1) 1/6" hex key



Cabling

The IMS-4813 temperature sensor connects to the IMS-1000 via an RJ-45 cable (e.g. CAT5 cable). The connection from the sensor to the IMS-1000 can utilize your existing network wiring infrastructure. For example, the sensor may be installed in another room or another floor. Connect the sensor to your structured wiring network via an RJ-45 jack. At the other end, connect a patch cable from your structured wiring patch panel directly to the IMS-1000 environment input.



Caution: The IMS sensors are not TCP/IP devices and therefore should not be connected directly to any wiring infrastructure that is connected to network equipment such as a hub, router, or switch. Sensors use RJ-45 plugs and cables similar to those used with Ethernet devices.

Mounting

The temperature sensor can be mounted directly on a surface or attached to a single-gang electrical box. Consideration should be given to cable routing before attaching the sensor to the wall. Will the cable go through the wall (cable hidden) or will it run down the wall (cable visible)? Once this has been determined, run the cable to the location where the sensor will be installed.

Electrical box installation

Bring the RJ-45 cable through the electrical box. Remove the sensor cover by turning the two hex screws on the bottom of the sensor housing clockwise. Bring the cable through the back of the sensor and connect the cable to the jack as shown in Figure 1. Attach the sensor to the electrical box using the appropriate screws. Secure the sensor cover by turning the two hex screws on the bottom of the cover counterclockwise.

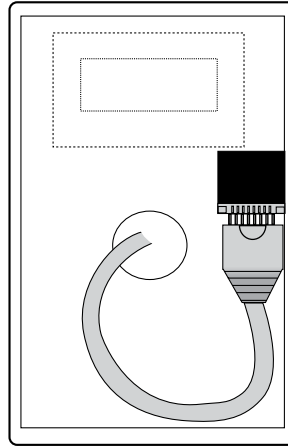

Figure 1: 4813 with Cable exiting through back of enclosure

Hidden cable surface installation

Bring the RJ-45 cable through the wall at the mounting location. Remove the sensor cover by turning the two hex screws on the bottom of the sensor housing clockwise. Bring the cable through the back of the sensor and hold the sensor housing against the wall. Use a pencil to mark the hole locations at the top and bottom of the housing. Remove the sensor from the wall. Install the drywall anchors (if necessary) to the wall. Bring the cable through the back of the sensor and connect it to the jack as shown in Figure 1. Attach the sensor to the wall using #6 tapping screws. Secure the sensor cover by turning the two hex screws on the bottom of the cover counterclockwise.

Visible cable surface installation

Remove the sensor cover by turning the two hex screws on the bottom of the sensor housing clockwise. Hold the sensor housing against the wall. Use a pencil to mark the hole locations at the top and bottom of the housing. Install the drywall anchors (if necessary) to the wall. Attach the sensor to the wall using #6 tapping screws. Connect the cable to the jack as shown in Figure 2. Secure the sensor cover by turning the two hex screws on the bottom of the cover counterclockwise.

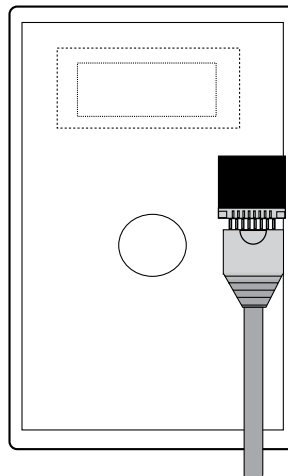

Figure 2: 4813 with Cable exiting out enclosure bottom

Configuration

All IMS Solution sensors are auto-configured when you plug them into the IMS-1000. When a new sensor is plugged into the IMS-1000, the configuration is set to the factory default via the *Sensor Template*. If you have modified these templates, the configuration will be set to the modified configuration. When a sensor is removed, or the connection is disrupted, the configuration data remains intact but the sensor will go into trouble status and generate a trouble alarm. When the sensor is plugged in again, or the connection is re-established, configuration data remains unchanged and the sensor returns to normal operating condition.



Caution: Removing a sensor for less than 60 seconds does not produce a trouble alarm. Removing or unplugging a sensor for more than 60 seconds or plugging in a different sensor at any time will cause a trouble alarm.

Sensor Template (*factory default*)

Input Name:	Temperature
Low Temperature Limit:	10° C
High Temperature Limit:	27° C
Recognition Time:	60 Seconds
Reset Time:	0 Seconds
Data Logging:	Active
Voice:	temperature.wav
Input Class:	Temperature

Specifications

Range:	0 to 35 degrees C
Humidity:	5–90 %RH
Sensor type:	solid state ic
Accuracy:	+/- 1.7 degrees C
Connector:	RJ-45
Housing:	white plastic

IMS-4814 Ultra Low Temperature Sensor

Installation Instructions

Introduction

The IMS-4814 Ultra Low Temperature Sensor is designed to connect to the IMS-1000 and monitor temperatures in refrigerators or freezers. The electrical connection between the sensor and IMS-1000 is made via the attached RJ-45 patch cable. The sensor probe may be secured inside equipment using the included clamp or it may be hung using tie wraps. Do not install the black plastic enclosure inside of a refrigerator or freezer.



Cabling

The Ultra Low Temperature Sensor comes with an attached 7' cable with an RJ-45 plug on the end and a weatherproof probe with 12' of cable. If the sensor installation is close to the IMS-1000, you can plug it directly into an IMS environmental input. If the cable is too short you can use the included RJ-45 adaptor and a longer patch cable to extend the length. For applications where the sensor may be far from the IMS unit, you may utilize your existing network wiring infrastructure. For example, the sensor may be installed in another room or another floor. Connect the sensor to your structured wiring network via an RJ-45 jack. At the other end, connect a patch cable from your structured wiring patch panel directly to the IMS-1000 environment input.



Caution: The IMS sensors are not TCP/IP devices and therefore should not be connected directly to any wiring infrastructure that is connected to network equipment such as a hub, router, or switch. Sensors use RJ-45 plugs and cables similar to those used with Ethernet devices.

Mounting

The temperature sensor housing may be mounted directly on a surface using double-sided tape (included) or it may be secured to equipment using tie-wraps. The choice depends on your application. The sensor probe must be installed in your refrigerator or freezer at a location that is representative of the average temperature. Do not install the probe directly in front of the cold air blower.

Configuration

All IMS Solution sensors are auto-configured when you plug them into the IMS-1000. The Ultra Low Temperature Sensor will identify itself as a 4-20mA transducer. On the Properties screen for this sensor you must select the sensor type: either Low Temperature (Deg F) or Low Temperature (Deg C). When a sensor is removed, or the connection is disrupted, the configuration data remains intact but the sensor will go into trouble status and generate a trouble alarm. When the sensor is plugged in again, or the connection is re-established, configuration data remains unchanged and the sensor returns to normal operating condition.



Caution: Removing a sensor for less than 60 seconds does not produce a trouble alarm. Removing or unplugging a sensor for more than 60 seconds or plugging in a different sensor at any time will cause a trouble alarm.

Sensor Template

Input Name: Transducer

High Limit: 100

Low Limit: 0

Recognition Time: 3 Seconds

Reset Time: 0 Seconds

Data Logging: Active

Voice: None

Input Class: Other

Weight: 3 oz (85 grams)

Specifications

Temperature Range: -122 to 53°F (-86 to 12°C)

Humidity: 5–90% RH

Sensor type: sealed thermistor probe

Accuracy: +/- 3 degrees F

Connector: 7' cable w/RJ-45 plug

Housing: black plastic

Housing dimensions: 2.13" l x 0.6" d x 1.38" h

IMS-4820 Room Humidity Sensor

Installation Instructions

Introduction

The IMS-4820 humidity sensor is designed to connect to the IMS-1000 and monitor indoor humidity levels. The electrical connection between the sensor and IMS-1000 is made via RJ-45 patch cable (not included). The sensor may be mounted either on a wall or to a single-gang electrical box.

Package Contents

- (1) IMS-4820 Humidity sensor
- (2) Plastic drywall anchors
- (2) #6 Metal tapping screws
- (1) 1/16" hex key



Cabling

The humidity sensor connects to the IMS-1000 via an RJ-45 cable (e.g. CAT5 cable). The connection from the sensor to the IMS-1000 can utilize your existing network wiring infrastructure. For example, the sensor may be installed in another room or another floor. Connect the sensor to your structured wiring network via an RJ-45 jack. At the other end, connect a patch cable from your structured wiring patch panel directly to the IMS-1000 environment input.



Caution: The IMS sensors are not TCP/IP devices and therefore should not be connected directly to any wiring infrastructure that is connected to network equipment such as a hub, router, or switch. Sensors use RJ-45 plugs and cables similar to those used with Ethernet devices.

Mounting

The humidity sensor can be mounted directly on a surface or attached to a single-gang electrical box. Consideration should be given to cable routing before attaching the sensor to the wall. Will the cable go through the wall (cable hidden) or will it run down the wall (cable visible)? Once this has been determined, run the cable to the location where the sensor will be installed.

Electrical box installation

Bring the RJ-45 cable through the electrical box. Remove the sensor cover by turning the two hex screws on the bottom of the sensor housing clockwise. Bring the cable through the back of the sensor and connect the cable to the jack as shown in Figure 1. Attach the sensor to the electrical box using the appropriate screws. Secure the sensor cover by turning the two hex screws on the bottom of the cover counterclockwise.

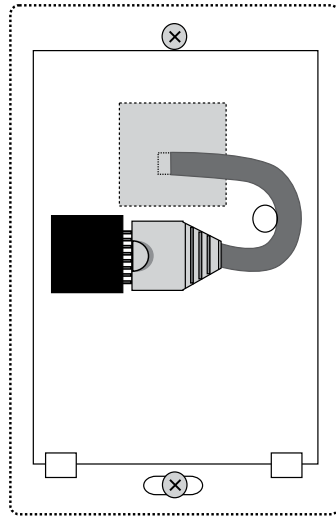

Figure 1: 4820 with Cable exiting through back of enclosure

Hidden cable surface installation

Bring the RJ-45 cable through the wall at the mounting location. Remove the sensor cover by turning the two hex screws on the bottom of the sensor housing clockwise. Bring the cable through the back of the sensor and hold the sensor housing against the wall. Use a pencil to mark the hole locations at the top and bottom of the housing. Remove the sensor from the wall. Install the drywall anchors (if necessary) to the wall. Bring the cable through the back of the sensor and connect it to the jack as shown in Figure 1. Attach the sensor to the wall using #6 tapping screws. Secure the sensor cover by turning the two hex screws on the bottom of the cover counterclockwise.

Visible cable surface installation

Remove the sensor cover by turning the two hex screws on the bottom of the sensor housing clockwise. Hold the sensor housing against the wall. Use a pencil to mark the hole locations at the top and bottom of the housing. Install the drywall anchors (if necessary) to the wall. Attach the sensor to the wall using #6 tapping screws. Connect the cable to the jack as shown in Figure 2. Secure the sensor cover by turning the two hex screws on the bottom of the cover counterclockwise.

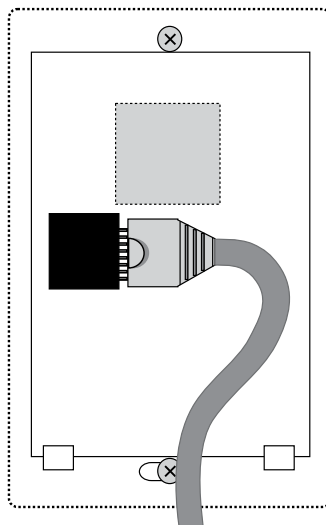

Figure 2: 4820 with Cable exiting out enclosure bottom

Configuration

All IMS Solution sensors are auto-configured when you plug them into the IMS-1000. When a new sensor is plugged into the IMS-1000, the configuration is set to the factory default via the Sensor Template. If you have modified these templates, the configuration will be set to the modified configuration. When a sensor is removed, or the connection is disrupted, the configuration data remains intact but the sensor will go into trouble status and generate a trouble alarm. When the sensor is plugged in again, or the connection is re-established, configuration data remains unchanged and the sensor returns to normal operating condition.



Caution: Removing a sensor for less than 60 seconds does not produce a trouble alarm. Removing or unplugging a sensor for more than 60 seconds or plugging in a different sensor at any time will cause a trouble alarm.

Sensor Template (*factory default*)

Input Name:	Humidity
Low Limit:	20%
High Limit:	60%
Recognition Time:	60 Seconds
Reset Time:	0 Seconds
Data Logging:	Active
Voice:	humidity.wav
Input Class:	Humidity

Specifications

Range:	0–100% RH
Temperature:	32–122° F (0–50° C)
Accuracy:	+/- 5%
Connector:	RJ-45
Housing:	white plastic

IMS-4821 Room Humidity Sensor with display

Installation Instructions

Introduction

The IMS-4821 humidity sensor is designed to connect to the IMS-1000 and monitor indoor humidity. The electrical connection between the sensor and IMS-1000 is made via RJ-45 patch cable (not included). The sensor may be mounted either on a wall or to a single-gang electrical box.

Package Contents

- (1) IMS-4821 Humidity sensor
- (2) Plastic drywall anchors
- (2) #6 Metal tapping screws
- (1) 1/16" hex key



Cabling

The humidity sensor connects to the IMS-1000 via an RJ-45 cable (e.g. CAT5 cable). The connection from the sensor to the IMS-1000 can utilize your existing network wiring infrastructure. For example, the sensor may be installed in another room or another floor. Connect the sensor to your structured wiring network via an RJ-45 jack. At the other end, connect a patch cable from your structured wiring patch panel directly to the IMS-1000 environment input.



Caution: The IMS sensors are not TCP/IP devices and therefore should not be connected directly to any wiring infrastructure that is connected to network equipment such as a hub, router, or switch. Sensors use RJ-45 plugs and cables similar to those used with Ethernet devices.

Mounting

The humidity sensor can be mounted directly on a surface or attached to a single-gang electrical box. Consideration should be given to cable routing before attaching the sensor to the wall. Will the cable go through the wall (cable hidden) or will it run down the wall (cable visible)? Once this has been determined, run the cable to the location where the sensor will be installed.

Electrical box installation

Bring the RJ-45 cable through the electrical box. Remove the sensor cover by turning the two hex screws on the bottom of the sensor housing clockwise. Bring the cable through the back of the sensor and connect the cable to the jack as shown in Figure 1. Attach the sensor to the electrical box using the appropriate screws. Secure the sensor cover by turning the two hex screws on the bottom of the cover counterclockwise.

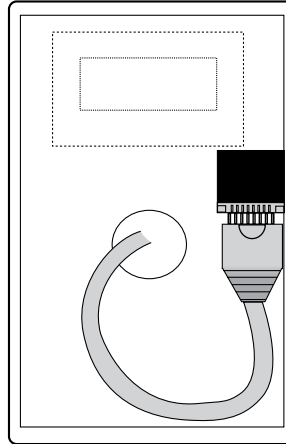

Figure 1: 4821 with Cable exiting through back of enclosure

Hidden cable surface installation

Bring the RJ-45 cable through the wall at the mounting location. Remove the sensor cover by turning the two hex screws on the bottom of the sensor housing clockwise. Bring the cable through the back of the sensor and hold the sensor housing against the wall. Use a pencil to mark the hole locations at the top and bottom of the housing. Remove the sensor from the wall. Install the drywall anchors (if necessary) to the wall. Bring the cable through the back of the sensor and connect it to the jack as shown in Figure 1. Attach the sensor to the wall using #6 tapping screws. Secure the sensor cover by turning the two hex screws on the bottom of the cover counterclockwise.

Visible cable surface installation

Remove the sensor cover by turning the two hex screws on the bottom of the sensor housing clockwise. Hold the sensor housing against the wall. Use a pencil to mark the hole locations at the top and bottom of the housing. Install the drywall anchors (if necessary) to the wall. Attach the sensor to the wall using #6 tapping screws. Connect the cable to the jack as shown in Figure 2. Secure the sensor cover by turning the two hex screws on the bottom of the cover counterclockwise.

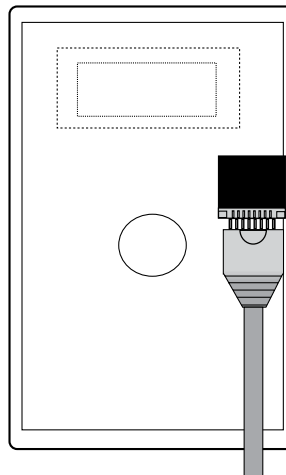

Figure 2: 4821 with Cable exiting out enclosure bottom

Configuration

All IMS Solution sensors are auto-configured when you plug them into the IMS-1000. When a new sensor is plugged into the IMS-1000, the configuration is set to the factory default via the *Sensor Template*. If you have modified these templates, the configuration will be set to the modified configuration. When a sensor is removed, or the connection is disrupted, the configuration data remains intact but the sensor will go into trouble status and generate a trouble alarm. When the sensor is plugged in again, or the connection is re-established, configuration data remains unchanged and the sensor returns to normal operating condition.



Caution: Removing a sensor for less than 60 seconds does not produce a trouble alarm. Removing or unplugging a sensor for more than 60 seconds or plugging in a different sensor at any time will cause a trouble alarm.

Sensor Template (*factory default*)

Input Name:	Humidity
Low Limit:	20%
High Limit:	60%
Recognition Time:	60 Seconds
Reset Time:	0 Seconds
Data Logging:	Active
Voice:	humidity.wav
Input Class:	Humidity

Specifications

Range:	5–95%
Temperature:	32–158° F (0–70° C)
Accuracy:	+/- 3%
Connector:	RJ-45
Housing:	white plastic

IMS-4830 Water Detection Sensor

Installation Instructions

Introduction

The IMS-4830 Water Detection Sensor protects your server and equipment from damaging water leaks from malfunctioning HVAC systems, cafeteria accidents, or any general plumbing failures in your facilities. The IMS-4830 is powered directly by the IMS-1000 unit.

After mounting the sensor, attach the included WaterRope, and simply lay its orange cable around your equipment: place it on the floor or beneath a raised floor; inside a drop-ceiling or in the rafters between floors; or anywhere you must know about water near your equipment.



You can attach additional Water Detection sensors to each other to expand your water leak detection capabilities throughout your facility; alternatively, IMS WaterRopes are designed to plug into each other to widen your perimeter for any individual sensor.

Package Contents

- (1) IMS-4830 Water Detection Sensor
- (1) 10' of WaterRope
- (5) Adhesive cable clamps
- (2) Plastic drywall anchors
- (2) #6 Metal tapping screws
- (4) Rubber feet

Cabling

The water detection sensor connects to the IMS-1000 via an RJ-45 cable (e.g. CAT5 cable). The connection from the sensor to the IMS-1000 can utilize your existing network wiring infrastructure. For example, the sensor may be installed in another room or another floor. Connect the sensor to your structured wiring network via an RJ-45 jack. At the other end, connect a patch cable from your structured wiring patch panel directly to the IMS-1000 environment input.



Caution: The IMS sensors are not TCP/IP devices and therefore should not be connected directly to any wiring infrastructure that is connected to network equipment such as a hub, router, or switch. Sensors use RJ-45 plugs and cables similar to those used with Ethernet devices.

Extending the WaterRope

You can extend the monitored area by attaching additional pieces of WaterRope. Simply connect the new WaterRope to the end of the first. You can have up to ten (10) pieces of WaterRope (100') connected together from one Water Detection Sensor.

Cascading Water Sensors

You can cascade up to three Water Detection Sensors from a single IMS input channel. This is useful if there is a large distance between each sensor and you don't want to use up additional IMS inputs for individual sensors. Simply connect an RJ-45 cable to the *Next Sensor* jack on the first sensor to the IMS jack of the second sensor. See Figure below.

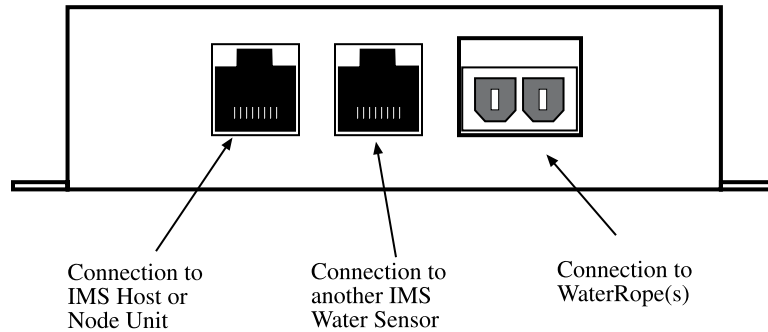

Figure 1: Sensor connections

Mounting

The sensor can be mounted to a wall or lie flat on the floor. To maximize the coverage of the WaterRope, install the sensor close to the area to be monitored. For wall mounting, install the Water Detection Sensor close to the floor. Install the two drywall anchors (if necessary) and attach the Water Detection Sensor using the two #6 tapping screws. When installing the sensor on the floor, attach the four rubber feet to the bottom of the enclosure.

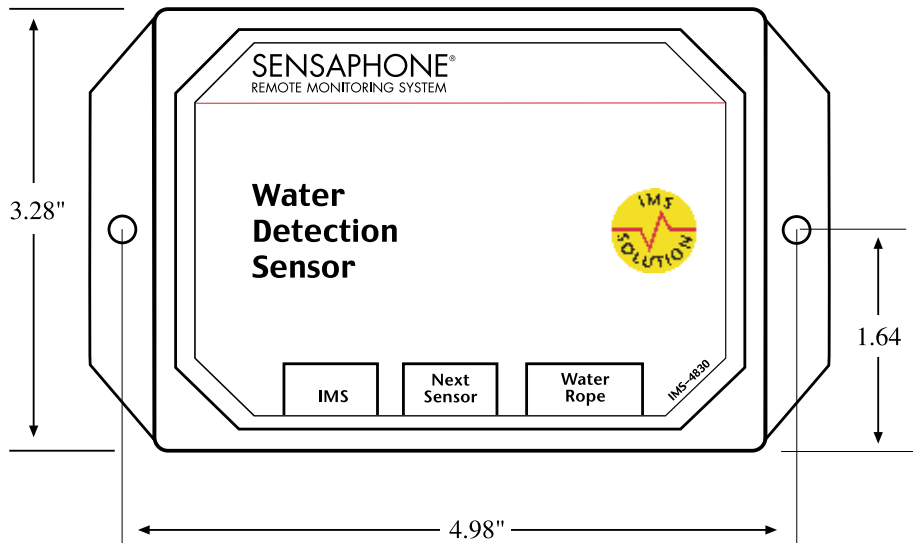

Figure 2: Mounting the sensor

Configuration

All IMS Solution sensors are auto-configured when you plug them into the IMS-1000. When a new sensor is plugged into the IMS-1000, the configuration is set to the factory default via the *Sensor Template*. If you have modified these templates, the configuration will be set to the modified configuration. When a sensor is removed, or the connection is disrupted, the configuration data remains intact but the sensor will go into trouble status and generate a trouble alarm. When the sensor is plugged in again, or the connection is re-established, configuration data remains unchanged and the sensor returns to normal operating condition.



Caution: Removing a sensor for less than 60 seconds does not produce a trouble alarm. Removing or unplugging a sensor for more than 60 seconds or plugging in a different sensor at any time will cause a trouble alarm.

Sensor Template (*factory default*)

Input Name: Water Sensor
Recognition Time: 3 Seconds
Reset Time: 0 Seconds
Data Logging: Active
Voice: water sensor.wav
Input Class: Water

Specifications

Sensing Method: Conductivity
Sensor: Polymer core cable with 2 sensing wires
IMS Connection: RJ-45
Housing: black plastic with mounting ears

IMS-4840 External Power Sensor

Installation Instructions

Introduction

The IMS-4840 External Power Sensor lets you monitor power anywhere within your infrastructure. It reports any loss of power and measures the current voltage in the circuit, allowing you to know the status of each server rack and even of your remote UPS. Any failed generator starts are reported to you immediately. The IMS-4840 can monitor voltage from 0–250VAC 50/60Hz.

Package Contents

- (1) IMS-4840 Power Sensor
- (2) Plastic drywall anchors
- (2) #6 Metal tapping screws
- (4) Rubber feet



Cabling

The Power Sensor connects to the IMS-1000 via an RJ-45 cable (e.g. CAT5 cable). The connection from the sensor to the IMS-1000 can utilize your existing network wiring infrastructure. For example, the sensor may be installed in another room or another floor. Connect the sensor to your structured wiring network via an RJ-45 jack. At the other end, connect a patch cable from your structured wiring patch panel directly to the IMS-1000 environment input.



Caution: The IMS sensors are not TCP/IP devices and therefore should not be connected directly to any wiring infrastructure that is connected to network equipment such as a hub, router, or switch. Sensors use RJ-45 plugs and cables similar to those used with Ethernet devices.

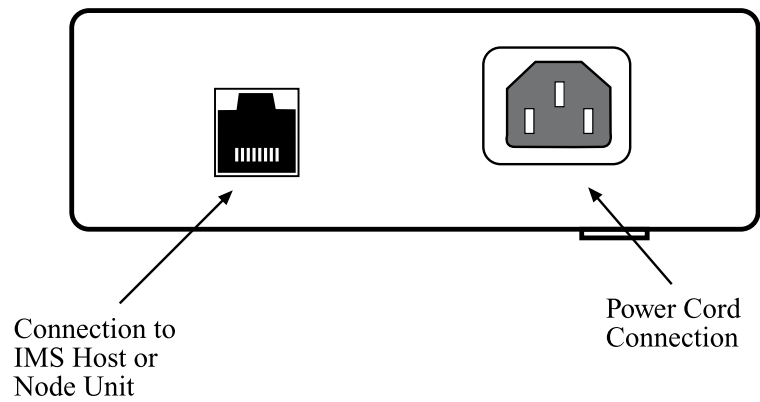

Figure 1: Connections to the IMS-4840

Mounting

The sensor can be mounted to a wall or lie flat on the floor. To mount the sensor to a wall, install the two drywall anchors (if necessary) and attach the Power Sensor using the two #6 tapping screws. When installing the sensor on the floor, attach the four rubber feet to the bottom of the enclosure.

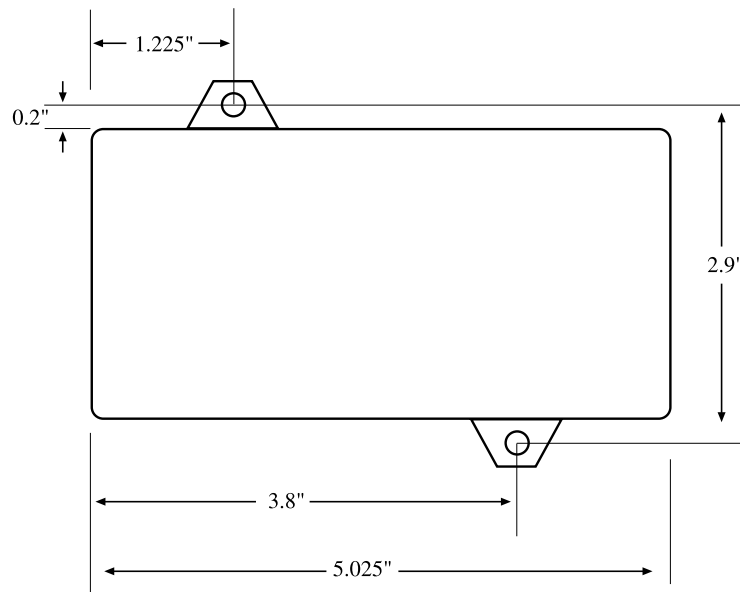

Figure 2: Mounting the sensor

Configuration

All IMS Solution sensors are auto-configured when you plug them into the IMS-1000. When a new sensor is plugged into the IMS-1000, the configuration is set to the factory default via the *Sensor Template*. If you have modified these templates, the configuration will be set to the modified configuration. When a sensor is removed, or the connection is disrupted, the configuration data remains intact but the sensor will go into trouble status and generate a trouble alarm. When the sensor is plugged in again, or the connection is re-established, configuration data remains unchanged and the sensor returns to normal operating condition.



Caution: Removing a sensor for less than 60 seconds does not produce a trouble alarm. Removing or unplugging a sensor for more than 60 seconds or plugging in a different sensor at any time will cause a trouble alarm.

Sensor Template (*factory default*)

Input Name:	Power
Low Limit:	90VAC
High Limit:	130VAC
Recognition Time:	60 Seconds
Reset Time:	0 Seconds
Data Logging:	Active
Voice:	power default.wav
Input Class:	Power

Specifications

Range:	0–250 VAC, 50/60 Hz
Accuracy:	± 2%
Power Connection:	universal IEC-320 power inlet
IMS Connection:	RJ-45
Housing:	Black plastic with mounting ears

IMS-4841 15A High Current Sensor

Installation Instructions

Introduction

The IMS-4841 15A Current Sensor lets you monitor current consumption of a particular device or circuit anywhere within your infrastructure. It reports the actual current flow in the circuit, allowing you to know the status of each server rack and even of your remote UPS. Any failed generator starts are reported to you immediately. The IMS-4841 can monitor current from 0-15 Amps over a voltage range from 0–250VAC 50/60Hz. The sensor comes with IEC320 C14 inlet and C13 outlet connectors.



Cabling

The Current Sensor connects to the IMS-1000 via an RJ-45 cable (e.g. CAT5 cable). The connection from the sensor to the IMS-1000 can utilize your existing network wiring infrastructure. For example, the sensor may be installed in another room or another floor. Connect the sensor to your structured wiring network via an RJ-45 jack. At the other end, connect a patch cable from your structured wiring patch panel directly to the IMS-1000 environment input.

⚠ Caution: The IMS sensors are not TCP/IP devices and therefore should not be connected directly to any wiring infrastructure that is connected to network equipment such as a hub, router, or switch. Sensors use RJ-45 plugs and cables similar to those used with Ethernet devices.

Connect your power source (120-250VAC 50/60Hz) to the inlet of the Current Sensor. Connect your device(s) to the outlet of the current sensor. Power cables are available to make these connections (see below):

Inlet Cable

IMS-4843 5-15P (US Style 3-prong plug) to IEC-320-C13, 10 ft

Outlet Cables

IMS-4844 IEC-320-C14 to NEMA 5-15R (US Style 3-prong receptacle), 1'

IMS-4845 IEC-60320-C14 to IEC-60320-C13, 10'

Mounting

The sensor can be mounted to a wall or lie flat on the floor. To mount the sensor to a wall, install four drywall anchors (if necessary) and attach the Current Sensor using four #6 tapping screws.

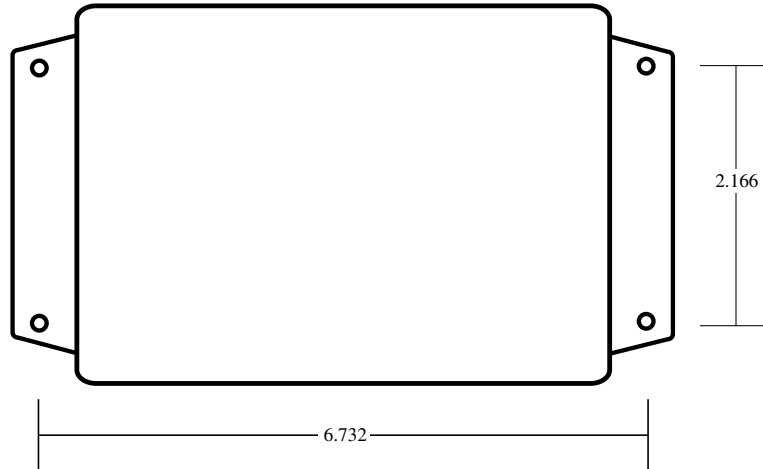

Figure 2: Mounting the sensor

Configuration

All IMS Solution sensors are auto-configured when you plug them into the IMS-1000. The 15A Current Sensor will identify itself as a 4-20mA transducer. On the Properties screen for this sensor you must select the sensor type: Current Sensor. When a sensor is removed, or the connection is disrupted, the configuration data remains intact but the sensor will go into trouble status and generate a trouble alarm. When the sensor is plugged in again, or the connection is re-established, configuration data remains unchanged and the sensor returns to normal operating condition.



Caution: Removing a sensor for less than 60 seconds does not produce a trouble alarm. Removing or unplugging a sensor for more than 60 seconds or plugging in a different sensor at any time will cause a trouble alarm.

Sensor Template (*factory default*)

Input Name: Transducer

High Limit: 100

Low Limit: 0

Recognition Time: 60 Seconds

Reset Time: 0 Seconds

Data Logging: Active

Voice: none

Input Class: Other

Specifications

Range: 0–15 Amps (0-250 VAC, 50/60 Hz)

Operating Temperature: 5-104°F (-15 to 40°C)

Operating Humidity: 0-95% RH, non–condensing

Accuracy: $\pm 2\%$ (from 1-100% of full–scale output)

Power Connection: IEC320-C14 inlet / IEC320-C13 outlet

IMS Connection: RJ-45

Housing: Black plastic with mounting ears

IMS-4842 20A High Current Sensor

Installation Instructions

Introduction

The IMS-4842 20A Current Sensor lets you monitor current consumption of a particular device or circuit anywhere within your infrastructure. It reports the actual current flow in the circuit, allowing you to know the status of each server rack and even of your remote UPS. Any failed generator starts are reported to you immediately. The IMS-4842 can monitor current from 0-20 Amps over a voltage range from 0–250VAC 50/60Hz. The sensor comes with IEC320 C20 inlet and C19 outlet connectors.



Cabling

The Current Sensor connects to the IMS-1000 via an RJ-45 cable (e.g. CAT5 cable). The connection from the sensor to the IMS-1000 can utilize your existing network wiring infrastructure. For example, the sensor may be installed in another room or another floor. Connect the sensor to your structured wiring network via an RJ-45 jack. At the other end, connect a patch cable from your structured wiring patch panel directly to the IMS-1000 environment input.



Caution: The IMS sensors are not TCP/IP devices and therefore should not be connected directly to any wiring infrastructure that is connected to network equipment such as a hub, router, or switch. Sensors use RJ-45 plugs and cables similar to those used with Ethernet devices.

Connect your power source (120-250VAC 50/60Hz) to the inlet of the Current Sensor. Connect your device(s) to the outlet of the current sensor. Heavy duty power cables are available to make these connections (see below):

IMS-4846 5-15P to IEC-320-C19, 10' Cable

IMS-4847 IEC-320-C20 to 5-15R, 1' Cable

IMS-4848 IEC-320-C20 to IEC-320-C19, 6' Cable

IMS-4849 IEC-320-C13 to IEC-320-C20, 7' Cable

Mounting

The sensor can be mounted to a wall or lie flat on the floor. To mount the sensor to a wall, install four drywall anchors (if necessary) and attach the Current Sensor using four #6 tapping screws.

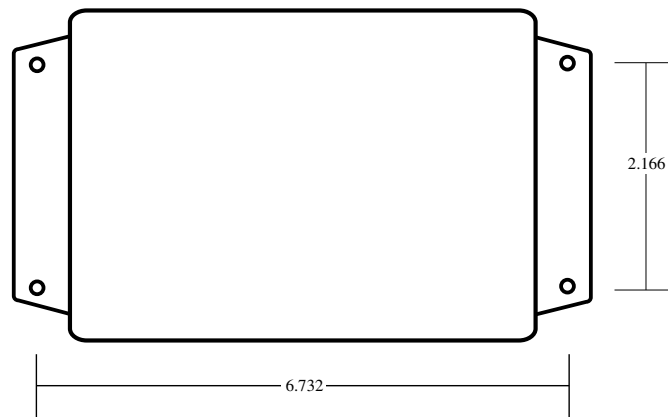

Figure 2: Mounting the sensor

Configuration

All IMS Solution sensors are auto-configured when you plug them into the IMS-1000. The 20A Current Sensor will identify itself as a 4-20mA transducer. On the Properties screen for this sensor you must select the sensor type: Current Sensor. When a sensor is removed, or the connection is disrupted, the configuration data remains intact but the sensor will go into trouble status and generate a trouble alarm. When the sensor is plugged in again, or the connection is re-established, configuration data remains unchanged and the sensor returns to normal operating condition.



Caution: Removing a sensor for less than 60 seconds does not produce a trouble alarm. Removing or unplugging a sensor for more than 60 seconds or plugging in a different sensor at any time will cause a trouble alarm.

Sensor Template (*factory default*)

Input Name: Transducer
 High Limit: 100
 Low Limit: 0
 Recognition Time: 60 Seconds
 Reset Time: 0 Seconds
 Data Logging: Active
 Voice: none
 Input Class: Other

Specifications

Range: 0-20 Amps (0-250 VAC, 50/60 Hz)
 Operating Temperature: 5-104 deg F (-15 to 40 deg C)
 Operating Humidity: 0 to 95% RH, non-condensing
 Accuracy: $\pm 2\%$ (from 1-100% of full-scale output)
 Power Connection: IEC320-C20 inlet/IEC320-C19 outlet
 IMS Connection: RJ-45
 Housing: Black plastic with mounting ears

IMS-4850 Dry Contact Bridge

Installation Instructions

Introduction

The IMS-1000 Dry Contact Bridge allows you to connect a dry contact alarm from any device to your IMS-1000. The Dry Contact Bridge is compatible with Normally Open and Normally Closed contacts. The electrical connection between the sensor and IMS-1000 is made via RJ-45 patch cable (not included). The sensor may be mounted either on a wall or rest on the floor.



Package Contents

- (1) IMS-4850 Dry Contact Bridge
- (2) Plastic drywall anchors
- (2) #6 Metal tapping screws
- (4) Rubber feet

Wiring the Contact

Connect your alarm contact to the terminal block labeled *Input*. Insert 1/2" stripped bare wire into the slot and tighten the screw. The slide switch selects between Normally Open (NO) and Normally Closed (NC) dry contacts. Place the switch in the appropriate position for the alarm contact you are monitoring.

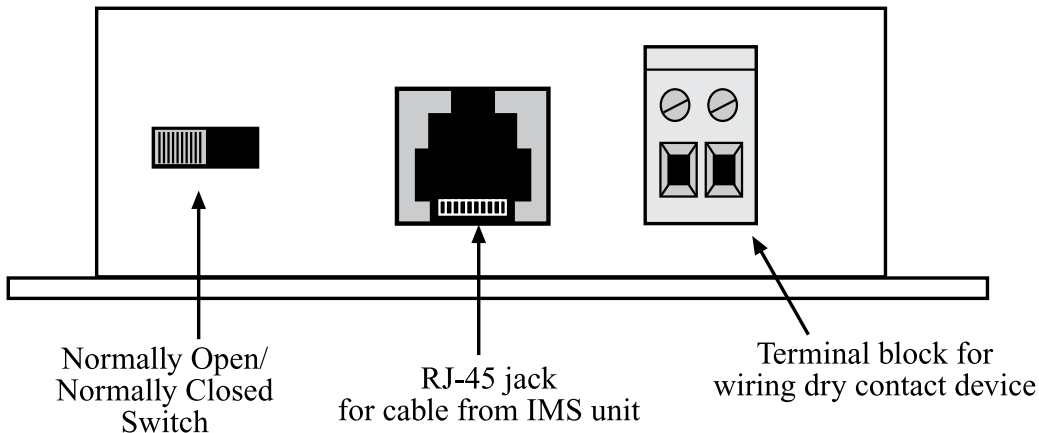

Figure 1: Connections to the IMS-4850

Cabling

The Dry Contact Bridge connects to the IMS-1000 via an RJ-45 cable (e.g. CAT5 cable). The connection from the sensor to the IMS-1000 can utilize your existing network wiring infrastructure. For example, the sensor may be installed in another room or another floor. Connect the bridge to your structured wiring network via an RJ-45 jack. At the other end, connect a patch cable from your structured wiring patch panel directly to the IMS-1000 environment input.

Caution: The IMS sensors are not TCP/IP devices and therefore should not be connected directly to any wiring infrastructure that is connected to network equipment such as a hub, router, or switch. Sensors use RJ-45 plugs and cables similar to those used with Ethernet devices.

Mounting

The Dry Contact Bridge can be mounted to a wall or lie flat on the floor. To mount it to a wall, install the two drywall anchors (if necessary) and attach the bridge using the two #6 tapping screws. When installing the sensor on the floor, attach the four rubber feet to the bottom of the enclosure.

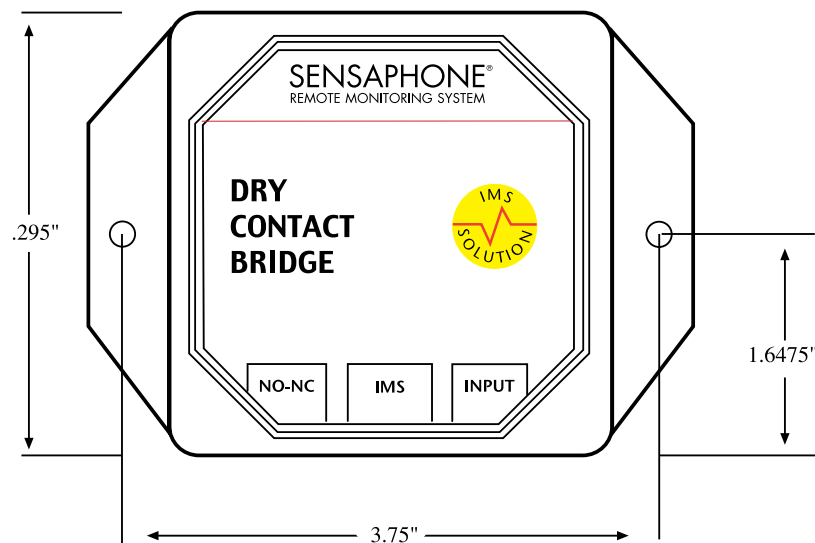

Figure 2: Mounting the sensor

Configuration

All IMS Solution sensors are auto-configured when you plug them into the IMS-1000. When a new sensor is plugged into the IMS-1000, the configuration is set to the factory default via the *Sensor Template*. If you have modified these templates, the configuration will be set to the modified configuration. When a sensor is removed, or the connection is disrupted, the configuration data remains intact but the sensor will go into trouble status and generate a trouble alarm. When the sensor is plugged in again, or the connection is re-established, configuration data remains unchanged and the sensor returns to normal operating condition.

Caution: Removing a sensor for less than 60 seconds does not produce a trouble alarm. Removing or unplugging a sensor for more than 60 seconds or plugging in a different sensor at any time will cause a trouble alarm.

Sensor Template (factory default)

Input Name: Contact Bridge
Recognition Time: 3 Seconds
Reset Time: 0 Seconds
Data Logging: Active
Voice: dry contact.wav
Input Class: Other

Specifications

Input: Normally Open or Normally Closed dry contact
Source/Sense Voltage: 14VDC
Source/Sense Current: 10mA
IMS Connection: RJ-45
Operating Temperature Range: 32-122 deg F (0-50 degC)
Housing: Black plastic with mounting ears

IMS-4851 4–20mA Bridge

Installation Instructions

Introduction

The IMS-1000 4–20mA Bridge allows you to connect a 4–20mA transducer to your IMS-1000. The 4–20mA Bridge features optical isolation between the input and the IMS-1000, which ensures trouble-free operation and safety. The electrical connection between the bridge and IMS-1000 is made via RJ-45 patch cable (not included). The bridge may be mounted either on a wall or rest on the floor.



Package Contents

- (1) IMS-4851 4–20mA Bridge
- (2) Plastic drywall anchors
- (2) #6 Metal tapping screws
- (4) Rubber feet

Wiring the Transducer

Connect your 4-20mA transducer to the terminal block labeled *Input* as shown in the figure below. Insert $\frac{1}{2}$ " stripped bare wire into the slot and tighten the screw. The Current Flow light will glow steadily when current is flowing into the bridge from the transducer. Note that a 4-20mA transducer typically requires you to have an external DC power supply for the transducer. A 24VDC supply is available from Sensaphone (FGD-0053).

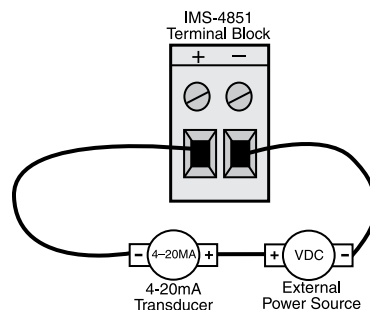

Figure 1: 4–20mA transducer wiring to IMS-4851 Terminal Block

Cabling

The 4-20mA Bridge connects to the IMS-1000 via an RJ-45 cable (e.g. CAT5 cable). The connection from the sensor to the IMS-1000 can utilize your existing network wiring infrastructure. For example, the bridge may be installed in another room or another floor. Connect the bridge to your structured wiring network via an RJ-45 jack. At the other end, connect a patch cable from your structured wiring patch panel directly to the IMS-1000 environment input.

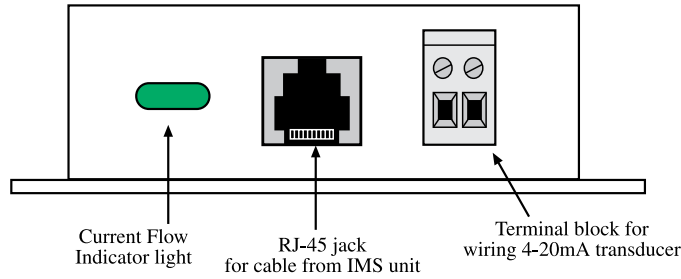

Figure 2: Connections to the IMS-4851

Caution: The IMS sensors are not TCP/IP devices and therefore should not be connected directly to any wiring infrastructure that is connected to network equipment such as a hub, router, or switch. Sensors use RJ-45 plugs and cables similar to those used with Ethernet devices.

Mounting

The 4-20mA Bridge can be mounted to a wall or lie flat on the floor. To mount it to a wall, install the two drywall anchors (if necessary) and attach the bridge using the two #6 tapping screws. When installing the sensor on the floor, attach the four rubber feet to the bottom of the enclosure.

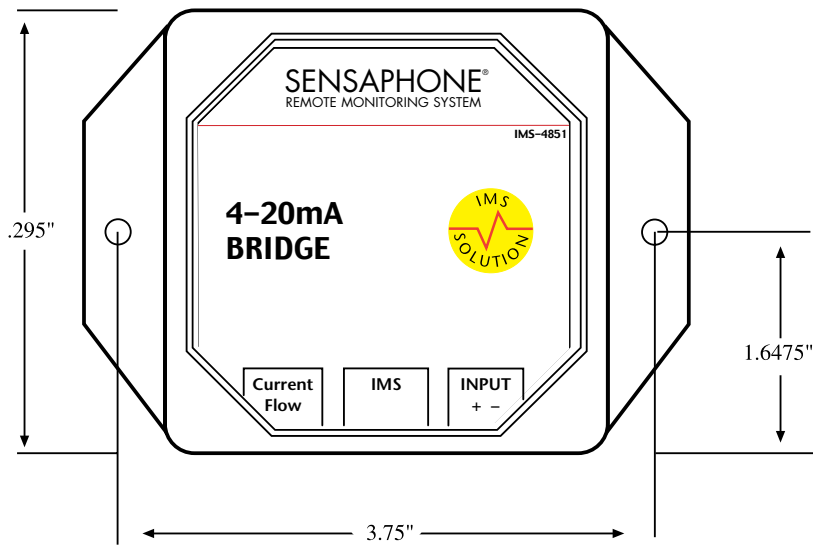

Figure 3: Mounting the sensor

Configuration

The 4-20mA Bridge has a fixed table range of 0-100% for a 4-20mA signal. This means that the displayed value in the ConsoleView software will be 0 to 100%. All IMS Solution sensors are auto-configured when you plug them into the IMS-1000. When a new sensor is plugged into the IMS-1000, the configuration is set to the factory default via the *Sensor Template*. If you have modified these templates, the configuration will be set to the modified configuration. When a sensor is removed, or the connection is disrupted, the configuration data remains intact but the sensor will go into trouble status and generate a trouble alarm. When the sensor is plugged in again, or the connection is re-established, configuration data remains unchanged and the sensor returns to normal operating condition.



Caution: Removing a sensor for less than 60 seconds does not produce a trouble alarm. Removing or unplugging a sensor for more than 60 seconds or plugging in a different sensor at any time will cause a trouble alarm.

Sensor Template (*factory default*)

Input Name: Transducer
 Recognition Time: 3 Seconds
 Reset Time: 0 Seconds
 Data Logging: Active
 Voice: None
 Input Class: Other

Specifications

Input: 4–20mA DC
 Current Limit: 50mA
 Input Impedance: Variable (1000 Ω @ 4mA, 260 Ω @ 20mA)
 Accuracy: $\pm 0.25\%$
 IMS Connection: RJ-45
 Operating Temperature Range: 32–122 deg F (0–50 degC)
 Housing: Black plastic with mounting ears

IMS-4860 Door Switch

Installation Instructions

Introduction

The IMS-1000 Door Switch with bridge enables your IMS-1000 to detect if any unauthorized entry or intrusion has occurred. The bridge may be mounted either on a wall or rest on the floor. The switch is mounted to doors or windows you wish to monitor. The electrical connection between the bridge and IMS-1000 is made via RJ-45 patch cable.



Package Contents

- (1) Door Switch with mounting hardware
- (1) IMS-4860 bridge
- (1) 25' accessory wire

Mounting the Door Switch

The door switch is usually installed to function in a normally closed position when the door (or window or other portal) on which it is mounted is closed. The complete assembly is of two parts: a magnet in a plastic housing, and a sensor switch with screw terminals in another plastic housing.

Mount the switch by fastening it to the non-moving frame surrounding the door or window. Use either mounting screws or the adhesive foam tape attached to the switch segments. Fasten the magnet near the edge of the movable sash or door. Position the magnet housing no more than 1/8" from the switch and tighten mounting screws. Use the spacer bar (included) if needed for alignment.

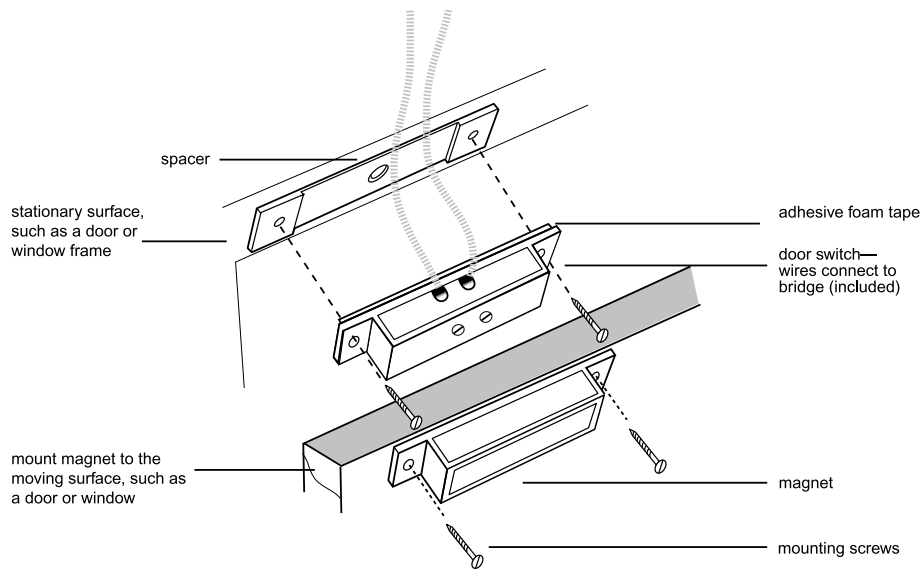

Figure 1: Door switch mounting

Mounting the Bridge

The bridge may be mounted directly on a surface using double-sided foam tape (included) or it may be secured to equipment using tie-wraps. The choice depends on your specific application.

Cabling

The Door Switch connects to the IMS-1000 via an RJ-45 cable (e.g. CAT5 cable) from the bridge. The connection from the bridge to IMS-1000 can utilize your existing network wiring infrastructure. For example, the switch may be installed in another room or another floor. Connect the bridge to your structured wiring network via an RJ-45 jack. At the other end, connect a patch cable from your structured wiring patch panel directly to the IMS-1000 environment input.



Caution: IMS sensors are not TCP/IP devices and therefore should not be connected directly to any wiring infrastructure that is connected to network equipment such as a hub, router, or switch. Sensors use RJ-45 plugs and cables similar to those used with Ethernet devices.

Configuration

All IMS Solution sensors are auto-configured when you plug them into the IMS-1000. When a new sensor is plugged into the IMS-1000, the configuration is set to the factory default via the *Sensor Template*. If you have modified these templates, the configuration will be set to the modified configuration. When a sensor is removed, or the connection is disrupted, the configuration data remains intact but the sensor will go into trouble status and generate a trouble alarm. When the sensor is plugged in again, or the connection is re-established, configuration data remains unchanged and the sensor returns to normal operating condition.



Caution: Removing a sensor for less than 60 seconds does not produce a trouble alarm. Removing or unplugging a sensor for more than 60 seconds or plugging in a different sensor at any time will cause a trouble alarm.

Sensor Template (*factory default*)

Input Name: Contact Bridge
Recognition Time: 3 Seconds
Reset Time: 0 Seconds
Data Logging: Active
Voice: dry contact.wav
Input Class: Other

Specifications

Bridge:

Input: Normally Open or Normally Closed dry contact
Source/Sense Voltage: 14VDC
Source/Sense Current: 10mA
Cable/Connector: 7' cable with RJ-45 plug
Operating Temperature Range: 32–122 deg F (0-50 degC)
Housing: Black plastic
Dimensions: 2.13" x 0.6" x 1.38"

Door Switch:

Normality: Normally Closed
Dimensions: 2.0" x 0.4" x 0.4" (part with screw terminals)
2.0" x 0.4" x 0.4" (part with magnet)

IMS-4861 Passive Infrared Detection Sensor

Installation Instructions

Introduction

The IMS-4861 Passive Infrared Detection Sensor is a dual-element passive infrared intrusion detector for use in electronic security systems. It reduces false alarms by eliminating background noises and nuisance stimuli. The IMS-4861 employs variable pulse-count adjustment, thus making it adaptable for use both inside and outside of server/equipment rooms. It is designed to connect to the IMS-1000. Refer to the manufacturer's instruction guide for more information.



Package Contents

- (1) IMS-4861 Passive Infrared Detection Sensor
- (2) Plastic drywall anchors
- (2) #6 Metal tapping screws

Cabling

The Passive Infrared Detection Sensor comes with an attached 7' cable with an RJ-45 plug on the end. If the sensor is close to the IMS-1000, you can plug the sensor directly to an IMS environmental input. If the cable is too short you can use the included RJ-45 adaptor and a longer patch cable to extend the length. For applications where the sensor may be far from the IMS unit, you may utilize your existing network wiring infrastructure. For example, the sensor may be installed in another room or another floor. Connect the sensor to your structured wiring network via an RJ-45 jack. At the other end, connect a patch cable from your structured wiring patch panel directly to the IMS-1000 environment input.



Caution: The IMS sensors are not TCP/IP devices and therefore should not be connected directly to any wiring infrastructure that is connected to network equipment such as a hub, router, or switch. Sensors use RJ-45 plugs and cables similar to those used with Ethernet devices.

Mounting

You should install the IMS-4861 sensor in a location that is most likely to intercept an intruder. The IMS-4861 monitors motion across a 90.5° field of vision and can detect motion across the beam as well as motion coming toward the sensor.

Note: Avoid installing the sensor where it faces direct sunlight; faces areas that may change temperature rapidly, or areas where there are air ducts or substantial air flows. All of these can create false reports.

The IMS-4861 can be installed by its bracket to either a wall or a ceiling. The bracket cover is used for mounting to walls. Remove the cover for ceiling mounting. (See Figure 1)

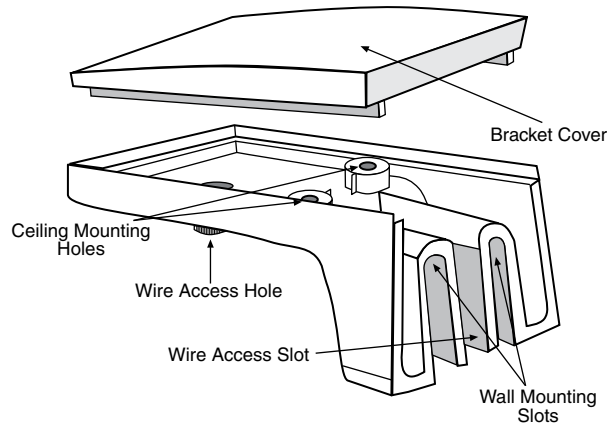

Figure 1: Mounting bracket

Run all cable wiring to the sensor through either the Wire Access Slot (wall mounted), or the Wire Access Hole (ceiling mounted).

The sensor can also be attached directly to a wall or corner without the bracket. Knockout holes for direct mounting can be accessed by opening the sensor body (see instructions below), taking out the PC board by removing the single screw that holds it in place, and then knocking out the appropriate four (4) holes: flat holes for direct mounting, or side (angled) holes for corner-mounting.

Configuration

All IMS Solution sensors are auto-configured when you plug them into the IMS-1000. When a new sensor is plugged into the IMS-1000, the configuration is set to the factory default via the *Sensor Template*. If you have modified these templates, the configuration will be set to the modified configuration. When a sensor is removed, or the connection is disrupted, the configuration data remains intact but the sensor will go into trouble status and generate a trouble alarm. When the sensor is plugged in again, or the connection is re-established, configuration data remains unchanged and the sensor returns to normal operating condition.



Caution: Removing a sensor for less than 60 seconds does not produce a trouble alarm. Removing or unplugging a sensor for more than 60 seconds or plugging in a different sensor at any time will cause a trouble alarm.

Sensitivity Adjustment

The sensitivity potentiometer should be adjusted according to the security risk level of the site. For high-risk locations, the sensitivity should be adjusted close to MIN (9%). In low risk situations, the sensitivity should be adjusted closer to MAX (100%). Default is 54%.

Note: Always walk-test and readjust as necessary.

Jumper Pin Selections

LED Selection Jumper

Jumper in position ON (to the left): LED is enabled. The LED will light when the sensor is in alarm condition.

Jumper in position OFF (to the right): LED is disabled.

PULSE/AUTO: Pulse Count Jumper

Jumper in position 1 (to the right): Jumper setting for a stable environment without air drafts.

Jumper in position AUTO (to the left): Setting for a harsh environment.

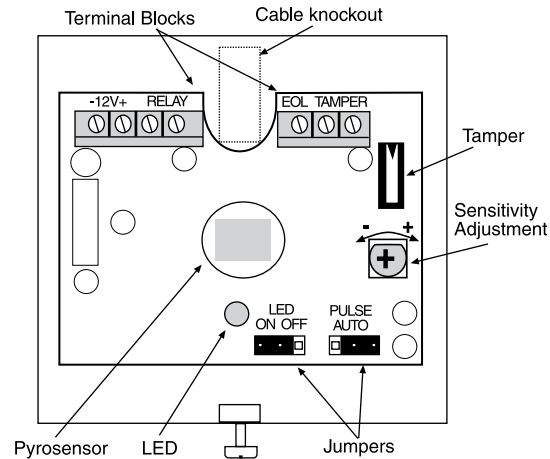

Figure 2: Sensitivity adjustment and jumper locations

Sensor Template (*factory default*)

Input Name:	Motion Detector
Recognition Time:	1 Second
Reset Time:	0 Seconds
Data Logging:	Active
Voice:	motion detector.wav
Input Class:	Other

Specifications

Pyrosensor:	Dual element type
Power Input:	8.2–16 Vdc
Current Consumption:	8mA @ 12 Vdc
Temperature Compensation:	Yes
Alarm Period:	2 sec (\pm 5sec)
Alarm Output:	N.C. 100mA @ 28 Vdc (10 Ω in line resistor Form “A”)
Tamper Switch:	N.C. 100mA @28 Vdc (10 Ω in line resistor Form “A”)-open
Operating ambient temperature range:	-4°F to +140°F (-20°C to +60°C)
Operating humidity range:	Up to 95% (non-condensing)
Storage temperature range:	-40°F to +176°F (-40°C to +80°C)
RFI protection:	\geq 30 V/m @ 10-1000 MHz
EMI immunity:	50,000 V electrical interference
Dimensions:	3.8" x 1.8" x2.5" (97mm x 63mm x 46.5mm)
Weight:	3 oz (85 grams)

IMS-4862 Smoke Detector Sensor

Installation Instructions

Introduction

The IMS-4862 Smoke Detector Sensor is designed to connect to the IMS-1000 and monitor for smoke in indoor environments. The electrical connection between the sensor and IMS-1000 is made via the attached RJ-45 patch cable. The sensor may be secured to a wall or ceiling (hardware not included).



Cabling

The Smoke Detector Sensor comes with an attached 7' cable with an RJ-45 plug on the end. If the sensor is close to the IMS-1000, you can plug the sensor directly to an IMS environmental input. If the cable is too short you can use the included RJ-45 adaptor and a longer patch cable to extend the length. For applications where the sensor may be far from the IMS unit, you may utilize your existing network wiring infrastructure. For example, the sensor may be installed in another room or another floor. Connect the sensor to your structured wiring network via an RJ-45 jack. At the other end, connect a patch cable from your structured wiring patch panel directly to the IMS-1000 environment input.

⚠ Caution: The IMS sensors are not TCP/IP devices and therefore should not be connected directly to any wiring infrastructure that is connected to network equipment such as a hub, router, or switch. Sensors use RJ-45 plugs and cables similar to those used with Ethernet devices.

Mounting

The sensor may be mounted directly against a wall or ceiling (hardware not included).

Configuration

All IMS Solution sensors are auto-configured when you plug them into the IMS-1000. When a new sensor is plugged into the IMS-1000, the configuration is set to the factory default via the *Sensor Template*. If you have modified these templates, the configuration will be set to the modified configuration. When a sensor is removed, or the connection is disrupted, the configuration data remains intact but the sensor will go into trouble status and generate a trouble alarm. When the sensor is plugged in again, or the connection is re-established, configuration data remains unchanged and the sensor returns to normal operating condition.

The smoke alarm is a latching alarm device. To reset the smoke alarm, momentarily disconnect the cable from the front panel of the IMS-1000 and then reconnect it.

⚠ Caution: Removing a sensor for less than 60 seconds does not produce a trouble alarm. Removing or unplugging a sensor for more than 60 seconds or plugging in a different sensor at any time will cause a trouble alarm.

Sensor Template (*factory default*)

Input Name: Smoke Detector
 Recognition Time: 10 Seconds
 Reset Time: 0 Seconds
 Data Logging: Active
 Voice: smoke detector.wav
 Input Class: Smoke

Specifications

Sensitivity: $2.0 \pm .37\% - .39\%$ /ft.
 Contact Rating: 2 AMP 28 VDC or 120 VAC resistive
 Heat sensor rating: Fixed 135° F (57°C) rate of rise > 15°F/min. (8.3°C/min.)
 Operating voltage: 8.5–33 VDC, 10% max. ripple
 Maximum ambient temperature: 100°F (37.8°C)
 Power-up time: 15 seconds
 Housing: white plastic
 Housing dimensions: 6.1" d x 1.9" h

Technical Support for the IMS-1000 Sensors

For questions about installing any of these sensors, please contact your local IMS Solution Reseller or VAR or contact the manufacturer directly at:

Phonetics, Inc.
901 Tryens Road
Aston, PA 19014
www.sensaphone.com

Tel: 610.558.2700
Fax: 610.558.0222
Email: sensaphone.com

Appendix A: Weekly Testing Procedure

We recommend that you test your IMS-1000 system weekly to be sure it is functioning properly. This will ensure that when a problem arises the IMS-1000 will be ready to alert the appropriate personnel. A test log template is included at the back of this manual.

There are several tests that can be performed:

1) Call the unit and listen to the Status Report. This will test the unit's ability to answer the phone and speak a message. It will also verify that all of the inputs are reading properly, the alarm conditions are OK, the electricity is on, the microphone is functioning, and the batteries are OK.

2) Create an alarm on each input by tripping all connected sensors.

Temperature sensors: Heat or cool the sensor.

Motion sensors: Have someone walk in front of the sensor.

Door/window sensors: open the door/window.

Water sensors: Apply a small amount of water beneath the sensor or use a wet towel and touch it to the sensor probes.

Humidity sensors: Raise the humidity around the sensor by holding a cup of very hot water beneath the sensor.

Smoke detectors: Hold magnet near test area on smoke detector, or make smoke.

Allow the unit to send its message all programmed contacts. This will make sure that the IMS-1000 is programmed properly. It will also prepare personnel to respond appropriately when they receive a call from the Sensaphone.

3) Test the batteries in any IMS unit by unplugging the AC power and making sure that the IMS-1000 continues to function.

4) If you require assistance, call Sensaphone Technical Support at 610.558.2700.

Appendix B: Troubleshooting

Software

Why does my IMS-1000 begin dialing as soon as I turn it on?

■ IMS-1000 will only dial to deliver an alarm message. An unacknowledged alarm exists, and IMS-1000 is trying to deliver an alarm message.

Why can't I connect with my IMS-1000 using my Ethernet network?

■ The IMS-1000's network settings may be incorrect. Verify the IP address, Gateway, DNS, and Subnet mask settings.

■ There may be a network IP address conflict. The IMS-1000's IP address may be the same as another device on your network.

Will IMS-1000 retain its programming if there has been a long power failure and the backup battery dies?

Yes. When all power is removed from the IMS-1000, voice messages and unit programming are retained in a nonvolatile solid-state flash disk.

My IMS-1000 unit got damaged and had to be replaced. Can I use the original unit's saved programming to quickly program the replacement unit?

Yes.

Why won't my IMS-1000 dial out?

■ Check that you have a Touch-Tone telephone line. The IMS-1000 will not be able to dial out if it's on a Pulse telephone line or a digital extension from a telephone system.

■ The Contact telephone number may be incorrectly programmed. Verify the telephone numbers. Is a '1 +area code' prefix required? Does your telephone line require a '9' prefix to reach an outside line?

■ Recognition time may be set too long for an alarm condition to become a valid alarm. Shorten the Recognition time for the alarm or increase the amount of time that the monitored condition exists.

■ 'Dial Out Attempts' might be set to zero. If this is the case, the IMS-1000 will make zero attempts to call the programmed Contacts. Increase 'Dial Out Attempts' to a number greater than zero.

I keep getting a busy signal when I call my IMS-1000 .

The IMS-1000 may be trying to deliver an alarm message.

Why does IMS-1000 call again with the same alarm after I just acknowledged it?

■ The alarm is clearing and quickly re-tripping. If this occurs, and the Alarm Recognition time is very short, the result will be another call for the re-tripped alarm. Increase the Alarm Recognition time to avoid rapid callbacks for the same alarm.

Appendix C: IMS-1000 Accessories

The accessories listed below are available from Phonetics, Inc. and our authorized distributors. Other dry contact sensors, designed for more specialized applications, may also be used. Commercial/industrial electrical supply houses can provide devices to monitor virtually any condition. For further information, contact Sensaphone Customer Service at 610.558.2700.

<u>Part Number</u>	<u>Description</u>
BAT-0006	6V 3.4AH battery
IMS-4402	IMS-1000 7' CAT5 Patch Cable
IMS-4403	IMS-1000 14' CAT5 Patch Cable
IMS-4404	IMS-1000 25' CAT5 Patch Cable
IMS-4405	IMS-1000 RJ-45 F/F Coupler Kit (4)
LIT-0143	IMS-1000 Solution Manual
IMS-4420	Axis Network Camera
IMS-4421	Panasonic Network Camera
IMS-4810	IMS-1000 Room Temperature Sensor
IMS-4811	IMS-1000 Room Temperature Sensor w/Display (Fahrenheit)
IMS-4812	IMS-1000 Mini-Temperature Sensor
IMS-4813	IMS-1000 Room Temperature Sensor w/Display (Celsius)
IMS-4814	IMS-1000 Ultra Low Temperature Sensor
IMS-4820	IMS-1000 Humidity Sensor
IMS-4821	IMS-1000 Humidity Sensor w/Display
IMS-4830	IMS-1000 Water Sensor w/10' Water Detection Rope
IMS-4831	IMS-1000 10' Water Detection Rope
IMS-4840	IMS-1000 Power Sensor
IMS-4841	IMS-1000 15A Current Sensor
IMS-4842	IMS-1000 20A Current Sensor
IMS-4850	IMS-1000 Dry Contact Bridge
IMS-4851	IMS-1000 4–20mA Bridge
IMS-4860	IMS-1000 Door Switch
IMS-4861	IMS-1000 Passive Infrared Motion Detector w/7' RJ-45 Cable
IMS-4862	IMS-1000 Smoke Detector w/7' RJ-45 Cable

Appendix D: Returning an IMS Unit for Repair

In the event that any of your Sensaphone IMS-1000 units does not function properly, we suggest that you do the following:

- 1) Record your observations regarding the individual unit's malfunction.
- 2) Call the Technical Service Department at 610.558.2700 prior to sending the unit to Senaphone for repair.

If the unit must be sent to Senaphone for Servicing, please do the following:

- 1) Turn the power switch on the rear of the unit Off.
- 2) Disconnect all cables, inputs and wiring, and unplug the unit.
- 3) Carefully pack the unit to avoid damage in transit. Use the original container (if available) or a sturdy shipping box.
- 4) To avoid shipping delays, you must include the following information :
 - a) Your name, address and telephone number.
 - b) A note explaining the problem.
- 5) Ship your package to the address below:

SERVICE DEPARTMENT
SENSAPHONE
901 Tryens Road
Aston, PA 19014

- 6) Ship prepaid and insured via UPS or US Mail to ensure a traceable shipment with recourse for damage or replacement.

Test Log

Date	Inputs	Dialout	Call-In	Battery		Tested By			
	Pass <input type="checkbox"/>	Fail <input type="checkbox"/>	Pass <input type="checkbox"/>	Fail <input type="checkbox"/>	Pass <input type="checkbox"/>	Fail <input type="checkbox"/>	Pass <input type="checkbox"/>	Fail <input type="checkbox"/>	
	Pass <input type="checkbox"/>	Fail <input type="checkbox"/>	Pass <input type="checkbox"/>	Fail <input type="checkbox"/>	Pass <input type="checkbox"/>	Fail <input type="checkbox"/>	Pass <input type="checkbox"/>	Fail <input type="checkbox"/>	
	Pass <input type="checkbox"/>	Fail <input type="checkbox"/>	Pass <input type="checkbox"/>	Fail <input type="checkbox"/>	Pass <input type="checkbox"/>	Fail <input type="checkbox"/>	Pass <input type="checkbox"/>	Fail <input type="checkbox"/>	
	Pass <input type="checkbox"/>	Fail <input type="checkbox"/>	Pass <input type="checkbox"/>	Fail <input type="checkbox"/>	Pass <input type="checkbox"/>	Fail <input type="checkbox"/>	Pass <input type="checkbox"/>	Fail <input type="checkbox"/>	
	Pass <input type="checkbox"/>	Fail <input type="checkbox"/>	Pass <input type="checkbox"/>	Fail <input type="checkbox"/>	Pass <input type="checkbox"/>	Fail <input type="checkbox"/>	Pass <input type="checkbox"/>	Fail <input type="checkbox"/>	
	Pass <input type="checkbox"/>	Fail <input type="checkbox"/>	Pass <input type="checkbox"/>	Fail <input type="checkbox"/>	Pass <input type="checkbox"/>	Fail <input type="checkbox"/>	Pass <input type="checkbox"/>	Fail <input type="checkbox"/>	
	Pass <input type="checkbox"/>	Fail <input type="checkbox"/>	Pass <input type="checkbox"/>	Fail <input type="checkbox"/>	Pass <input type="checkbox"/>	Fail <input type="checkbox"/>	Pass <input type="checkbox"/>	Fail <input type="checkbox"/>	
	Pass <input type="checkbox"/>	Fail <input type="checkbox"/>	Pass <input type="checkbox"/>	Fail <input type="checkbox"/>	Pass <input type="checkbox"/>	Fail <input type="checkbox"/>	Pass <input type="checkbox"/>	Fail <input type="checkbox"/>	
	Pass <input type="checkbox"/>	Fail <input type="checkbox"/>	Pass <input type="checkbox"/>	Fail <input type="checkbox"/>	Pass <input type="checkbox"/>	Fail <input type="checkbox"/>	Pass <input type="checkbox"/>	Fail <input type="checkbox"/>	
	Pass <input type="checkbox"/>	Fail <input type="checkbox"/>	Pass <input type="checkbox"/>	Fail <input type="checkbox"/>	Pass <input type="checkbox"/>	Fail <input type="checkbox"/>	Pass <input type="checkbox"/>	Fail <input type="checkbox"/>	
	Pass <input type="checkbox"/>	Fail <input type="checkbox"/>	Pass <input type="checkbox"/>	Fail <input type="checkbox"/>	Pass <input type="checkbox"/>	Fail <input type="checkbox"/>	Pass <input type="checkbox"/>	Fail <input type="checkbox"/>	
	Pass <input type="checkbox"/>	Fail <input type="checkbox"/>	Pass <input type="checkbox"/>	Fail <input type="checkbox"/>	Pass <input type="checkbox"/>	Fail <input type="checkbox"/>	Pass <input type="checkbox"/>	Fail <input type="checkbox"/>	
	Pass <input type="checkbox"/>	Fail <input type="checkbox"/>	Pass <input type="checkbox"/>	Fail <input type="checkbox"/>	Pass <input type="checkbox"/>	Fail <input type="checkbox"/>	Pass <input type="checkbox"/>	Fail <input type="checkbox"/>	
	Pass <input type="checkbox"/>	Fail <input type="checkbox"/>	Pass <input type="checkbox"/>	Fail <input type="checkbox"/>	Pass <input type="checkbox"/>	Fail <input type="checkbox"/>	Pass <input type="checkbox"/>	Fail <input type="checkbox"/>	
	Pass <input type="checkbox"/>	Fail <input type="checkbox"/>	Pass <input type="checkbox"/>	Fail <input type="checkbox"/>	Pass <input type="checkbox"/>	Fail <input type="checkbox"/>	Pass <input type="checkbox"/>	Fail <input type="checkbox"/>	
	Pass <input type="checkbox"/>	Fail <input type="checkbox"/>	Pass <input type="checkbox"/>	Fail <input type="checkbox"/>	Pass <input type="checkbox"/>	Fail <input type="checkbox"/>	Pass <input type="checkbox"/>	Fail <input type="checkbox"/>	
	Pass <input type="checkbox"/>	Fail <input type="checkbox"/>	Pass <input type="checkbox"/>	Fail <input type="checkbox"/>	Pass <input type="checkbox"/>	Fail <input type="checkbox"/>	Pass <input type="checkbox"/>	Fail <input type="checkbox"/>	
	Pass <input type="checkbox"/>	Fail <input type="checkbox"/>	Pass <input type="checkbox"/>	Fail <input type="checkbox"/>	Pass <input type="checkbox"/>	Fail <input type="checkbox"/>	Pass <input type="checkbox"/>	Fail <input type="checkbox"/>	
	Pass <input type="checkbox"/>	Fail <input type="checkbox"/>	Pass <input type="checkbox"/>	Fail <input type="checkbox"/>	Pass <input type="checkbox"/>	Fail <input type="checkbox"/>	Pass <input type="checkbox"/>	Fail <input type="checkbox"/>	

Date	Inputs	Dialout	Call-In	Battery		Tested By			
	Pass <input type="checkbox"/>	Fail <input type="checkbox"/>	Pass <input type="checkbox"/>	Fail <input type="checkbox"/>	Pass <input type="checkbox"/>	Fail <input type="checkbox"/>	Pass <input type="checkbox"/>	Fail <input type="checkbox"/>	
	Pass <input type="checkbox"/>	Fail <input type="checkbox"/>	Pass <input type="checkbox"/>	Fail <input type="checkbox"/>	Pass <input type="checkbox"/>	Fail <input type="checkbox"/>	Pass <input type="checkbox"/>	Fail <input type="checkbox"/>	
	Pass <input type="checkbox"/>	Fail <input type="checkbox"/>	Pass <input type="checkbox"/>	Fail <input type="checkbox"/>	Pass <input type="checkbox"/>	Fail <input type="checkbox"/>	Pass <input type="checkbox"/>	Fail <input type="checkbox"/>	
	Pass <input type="checkbox"/>	Fail <input type="checkbox"/>	Pass <input type="checkbox"/>	Fail <input type="checkbox"/>	Pass <input type="checkbox"/>	Fail <input type="checkbox"/>	Pass <input type="checkbox"/>	Fail <input type="checkbox"/>	
	Pass <input type="checkbox"/>	Fail <input type="checkbox"/>	Pass <input type="checkbox"/>	Fail <input type="checkbox"/>	Pass <input type="checkbox"/>	Fail <input type="checkbox"/>	Pass <input type="checkbox"/>	Fail <input type="checkbox"/>	
	Pass <input type="checkbox"/>	Fail <input type="checkbox"/>	Pass <input type="checkbox"/>	Fail <input type="checkbox"/>	Pass <input type="checkbox"/>	Fail <input type="checkbox"/>	Pass <input type="checkbox"/>	Fail <input type="checkbox"/>	
	Pass <input type="checkbox"/>	Fail <input type="checkbox"/>	Pass <input type="checkbox"/>	Fail <input type="checkbox"/>	Pass <input type="checkbox"/>	Fail <input type="checkbox"/>	Pass <input type="checkbox"/>	Fail <input type="checkbox"/>	
	Pass <input type="checkbox"/>	Fail <input type="checkbox"/>	Pass <input type="checkbox"/>	Fail <input type="checkbox"/>	Pass <input type="checkbox"/>	Fail <input type="checkbox"/>	Pass <input type="checkbox"/>	Fail <input type="checkbox"/>	
	Pass <input type="checkbox"/>	Fail <input type="checkbox"/>	Pass <input type="checkbox"/>	Fail <input type="checkbox"/>	Pass <input type="checkbox"/>	Fail <input type="checkbox"/>	Pass <input type="checkbox"/>	Fail <input type="checkbox"/>	
	Pass <input type="checkbox"/>	Fail <input type="checkbox"/>	Pass <input type="checkbox"/>	Fail <input type="checkbox"/>	Pass <input type="checkbox"/>	Fail <input type="checkbox"/>	Pass <input type="checkbox"/>	Fail <input type="checkbox"/>	
	Pass <input type="checkbox"/>	Fail <input type="checkbox"/>	Pass <input type="checkbox"/>	Fail <input type="checkbox"/>	Pass <input type="checkbox"/>	Fail <input type="checkbox"/>	Pass <input type="checkbox"/>	Fail <input type="checkbox"/>	
	Pass <input type="checkbox"/>	Fail <input type="checkbox"/>	Pass <input type="checkbox"/>	Fail <input type="checkbox"/>	Pass <input type="checkbox"/>	Fail <input type="checkbox"/>	Pass <input type="checkbox"/>	Fail <input type="checkbox"/>	
	Pass <input type="checkbox"/>	Fail <input type="checkbox"/>	Pass <input type="checkbox"/>	Fail <input type="checkbox"/>	Pass <input type="checkbox"/>	Fail <input type="checkbox"/>	Pass <input type="checkbox"/>	Fail <input type="checkbox"/>	
	Pass <input type="checkbox"/>	Fail <input type="checkbox"/>	Pass <input type="checkbox"/>	Fail <input type="checkbox"/>	Pass <input type="checkbox"/>	Fail <input type="checkbox"/>	Pass <input type="checkbox"/>	Fail <input type="checkbox"/>	
	Pass <input type="checkbox"/>	Fail <input type="checkbox"/>	Pass <input type="checkbox"/>	Fail <input type="checkbox"/>	Pass <input type="checkbox"/>	Fail <input type="checkbox"/>	Pass <input type="checkbox"/>	Fail <input type="checkbox"/>	
	Pass <input type="checkbox"/>	Fail <input type="checkbox"/>	Pass <input type="checkbox"/>	Fail <input type="checkbox"/>	Pass <input type="checkbox"/>	Fail <input type="checkbox"/>	Pass <input type="checkbox"/>	Fail <input type="checkbox"/>	
	Pass <input type="checkbox"/>	Fail <input type="checkbox"/>	Pass <input type="checkbox"/>	Fail <input type="checkbox"/>	Pass <input type="checkbox"/>	Fail <input type="checkbox"/>	Pass <input type="checkbox"/>	Fail <input type="checkbox"/>	
	Pass <input type="checkbox"/>	Fail <input type="checkbox"/>	Pass <input type="checkbox"/>	Fail <input type="checkbox"/>	Pass <input type="checkbox"/>	Fail <input type="checkbox"/>	Pass <input type="checkbox"/>	Fail <input type="checkbox"/>	
	Pass <input type="checkbox"/>	Fail <input type="checkbox"/>	Pass <input type="checkbox"/>	Fail <input type="checkbox"/>	Pass <input type="checkbox"/>	Fail <input type="checkbox"/>	Pass <input type="checkbox"/>	Fail <input type="checkbox"/>	

Index

A

Accessories 104

Alarm

Delivery & Acknowledgment 50–52

Acknowledgment 50

Sample Alarm Messages 51–53

Environmental Input Alarm Logic 38–39

Message Pop-Ups 48–49

Response

Camera Snapshots on Alarm 44–45

Trouble Alarms 39

C

Canadian Department of Communications Statement vii

E

E-Mail 48–49

Setup 48–49

SMTP Error messages 48–49

Environmental Inputs

Configuring 37–39

Environmental Sensors

Removing/Changing a Sensor 39

F

FCC Requirements vi

Firmware

Updating 48–49

H

History 47–49

Archiving the Database 48

Copying to the Clipboard 48

Deleting Data 48

Exporting Data 48

Host

Battery Maintenance 27–28

Installation 22–24

Connecting Sensors 24

Operating Environment 23

Power On Self Test (POST) 23

Rack Mount 23

Tabletop 23

Wall Mount 23

Network Configuration 24–27

Rear Panel 22

Specifications 30

I

IP Alarms

Alarm Logic 41–42

Configuring 39–41

Setup 39–40

Programming Alarm Parameters 39–40

Removing 43

Q

Quick Start Guide

Configure the Unit Properties 31

Default Username and Password 31

R

Realtime Strip Chart 38

S

Sensors 56–101

IMS-4810 Room Temperature Sensor 56–59

Cabling 56

Configuration 58

Mounting 56–58

Specifications & Defaults 59

IMS-4811 Room Temperature Sensor with display (F) 59–61

Cabling 60

Configuration 62

Mounting 60–61

Specifications & Defaults 62

IMS-4812 Mini-Temperature Sensor (F) 62–63

Cabling 63

Configuration 63

Mounting 63

Specifications 64–101

IMS-4813 Room Temperature Sensor with display (C) 65–67

Cabling 65

Configuration 67

Mounting 65–66

Specifications 67–101

IMS-4820 Room Humidity Sensor 69–71

Cabling 70

Configuration 72

Mounting 70–71

Specifications 72–101

IMS-4821 Room Humidity Sensor with display 73–75

Cabling 73

Configuration 75

Mounting 73–74

Specifications & Defaults 75

IMS-4830 Water Detection Sensor 76–78

Cabling 76

Configuration 77–78

Extending the WaterRope 76–77

Cascading Water Sensors 77

Mounting 77

Specifications & Defaults 78–101

IMS-4840 External Power Sensor 79–81

Cabling 79–80, 82, 85

Configuration 80, 83, 86

Mounting 80, 83, 85–86

IMS-1000 Manual

- Specifications & Defaults 81–101, 84–101, 86–101
- IMS-4850 Dry Contact Bridge 82–84
 - Cabling 87–88
 - Configuration 88
 - Mounting 88
 - Specifications & Defaults 89–101
 - Wiring the Contact 87
- IMS-4851 4-20mA Bridge
 - Cabling 90–91
 - Configuration 91–92
 - IMS-4851 4-20mA Bridge 90–92
 - Mounting 91
 - Specifications & Defaults 92–101
 - Wiring the Transducer 90
- IMS-4860 Door Switch 93–95
 - Cabling 94
 - Configuration 94
 - Mounting 93–94
 - Specifications & Defaults 95–101
- IMS-4861 Passive Infrared Detection Sensor 96–98
 - Cabling 68, 96
 - Configuration 68–69, 97
 - Jumper Pin Selections 97–98
 - Mounting 68–69, 96–97
 - Sensitivity Adjustment 97
 - Specifications & Defaults 98
- IMS-4862 Smoke Detector Sensor 99–100
 - Cabling 99
 - Configuration 99
 - Mounting 99
 - Specifications & Defaults 100
- Technical Support for 68, 101
- SNMP 54–55

T

- Technical Support 19
- Telephone Consumer Protection Act vii
- Test Log Templates 106–107

U

- User Profiles
 - Contacts 35–36
 - Alphanumeric Pager Calls 36
 - E-mail 37
 - Fax Calls 37
 - Numeric Pager Calls 36
 - SNMP 37
 - Voice Calls 35–36, 36
 - Deleting 35
- User Profiles and Contacts
 - Configuring 34–35

V

- Video Camera
 - Configuring 44–45
- Voice Status Report & Touch-Tone Commands 51–53
 - Remote Login via Dialup 53
 - User Specific Reports 52

- Sample Status Report 52
- Voice Alarm Dialout 52–53

W

- Warranty ix–x
- Web Page
 - Updating 47
- Weekly Testing Procedure 102